

INITIAL RESULTS FROM THE MST REVERSED FIELD PINCH

(Poster presented at the 30th Annual Meeting of the
Division of Plasma Physics of the American Physical Society
October 31-November 4, 1988, Hollywood, FL)

J.A. Beckstead
A.F. Almagri
S. Assadi
G. Chartas
X. Deng
D.J. Den Hartog
R.N. Dexter
S.A. Hokin
D.W. Kerst
D. Kortbawi
T.W. Lovell
S.C. Prager
T.D. Rempel
J.S. Sarff
E.E. Scime
W. Shen
C.W. Spragins
J.C. Sprott

PLP 1045

December 1988

Plasma Studies

University of Wisconsin

These PLP Reports are informal and preliminary and as such may contain errors not yet eliminated. They are for private circulation only and are not to be further transmitted without consent of the authors and major professor.

Abstract

Initial Results from the MST Reversed Field Pinch.*

J.A. Beckstead, A.F. Almagri, S. Assadi, G. Chartas, X. Deng, R.N. Dexter, D.J. Den Hartog, S.A. Hokin, D.W. Kerst, D. Kortbawi, T.W. Lovell, S.C. Prager, T.D. Rempel, J.S. Sarff, E.E. Scime, W. Shen, C.W. Spragins, and J.C. Sprott,
University of Wisconsin-Madison.

The MST (Madison Symmetric Torus) began operation in June 1988. The vacuum vessel has a 5-cm thick aluminum wall, major radius of 1.5 m, and a minor radius of 52 cm. It has an unconventional RFP design in that the vacuum vessel serves as the liner, the conducting shell, and the toroidal equilibrium field coils. The gap protection scheme acts as a limiter, 1 cm from the wall. Initial RFP results will be presented, as well as results of nonreversed operations.

*Work supported by U.S.D.O.E.

Outline

- 1) Design Features of MST
- 2) Physics Goals
- 3) Plasma Parameters
- 4) A Typical Shot
- 5) An Implied Temperature
- 6) F - Theta Scan @ Constant I_p
- 7) Sawteeth Like Oscillations
- 8) Conclusions and Future Work

Design Features of MST

MST was designed to minimize field errors, to allow for easy access to the machine, and to allow for easy disassembly.

This was accomplished by incorporating the following design features.

1) The vacuum vessel is made of 5 cm. thick Aluminum.

$R = 1.5 \text{ m.}$ and $a = 0.52 \text{ m.}$

- The vacuum vessel also acts as the toroidal field winding coil and the stabilizing conducting shell.

- This results in the toroidal and poloidal gaps being exposed to the plasma. They are protected by ceramic insulators being proven up to at least 400 Volts.

2) Pumping is done through a manifold.

- The manifold is connected to the vacuum vessel by 193 - 1 1/2 " Dia. holes.

- This decreases the field error due to larger pumping ports while maintaining a high pumping speed.

- 3) The poloidal field system will consist of three windings.
- A DC bias winding is used to obtain the full 2 weber flux swing of the iron core.
 - A poloidal field winding is positioned in order to closely match the wall currents at the poloidal gap. It is wrapped tightly around the core to allow easy diagnostic access to the vacuum vessel.
 - Continuity windings and a guard core prevent surface currents from flowing on the outer surface of the shell.
 - A poloidal flange is used to electrically connect the shell to the continuity windings. This allows for proper matching of the wall currents between the poloidal gap and the four legs of the continuity winding.
- 4) The vacuum vessel is used as the toriodal field winding.
- This reduces the toriodal field ripple due to a finite number of windings.
 - A toroidal flange is used to connect the vacuum vessel to four poloidal current feeds.

East View of MST

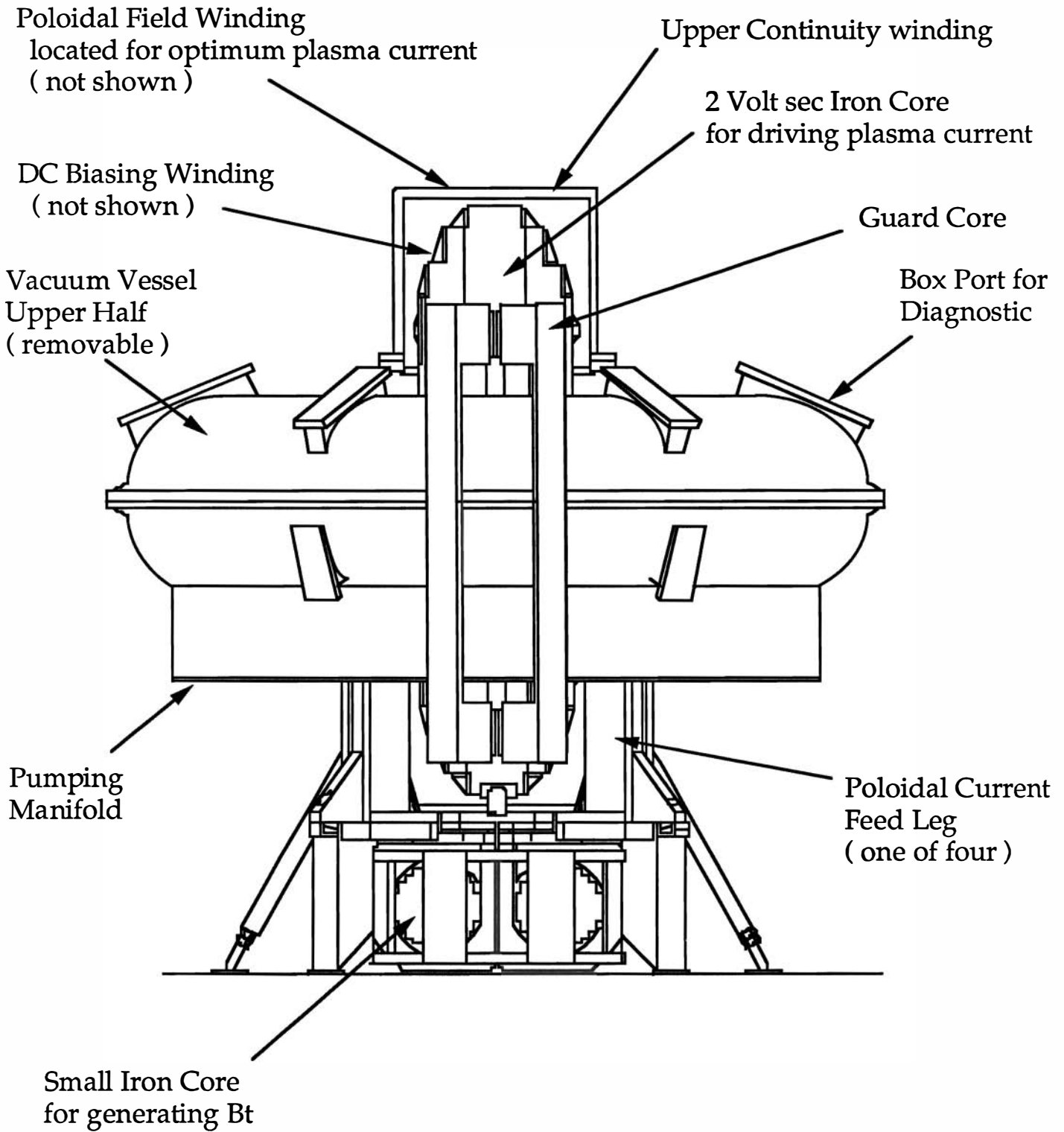

South View of MST

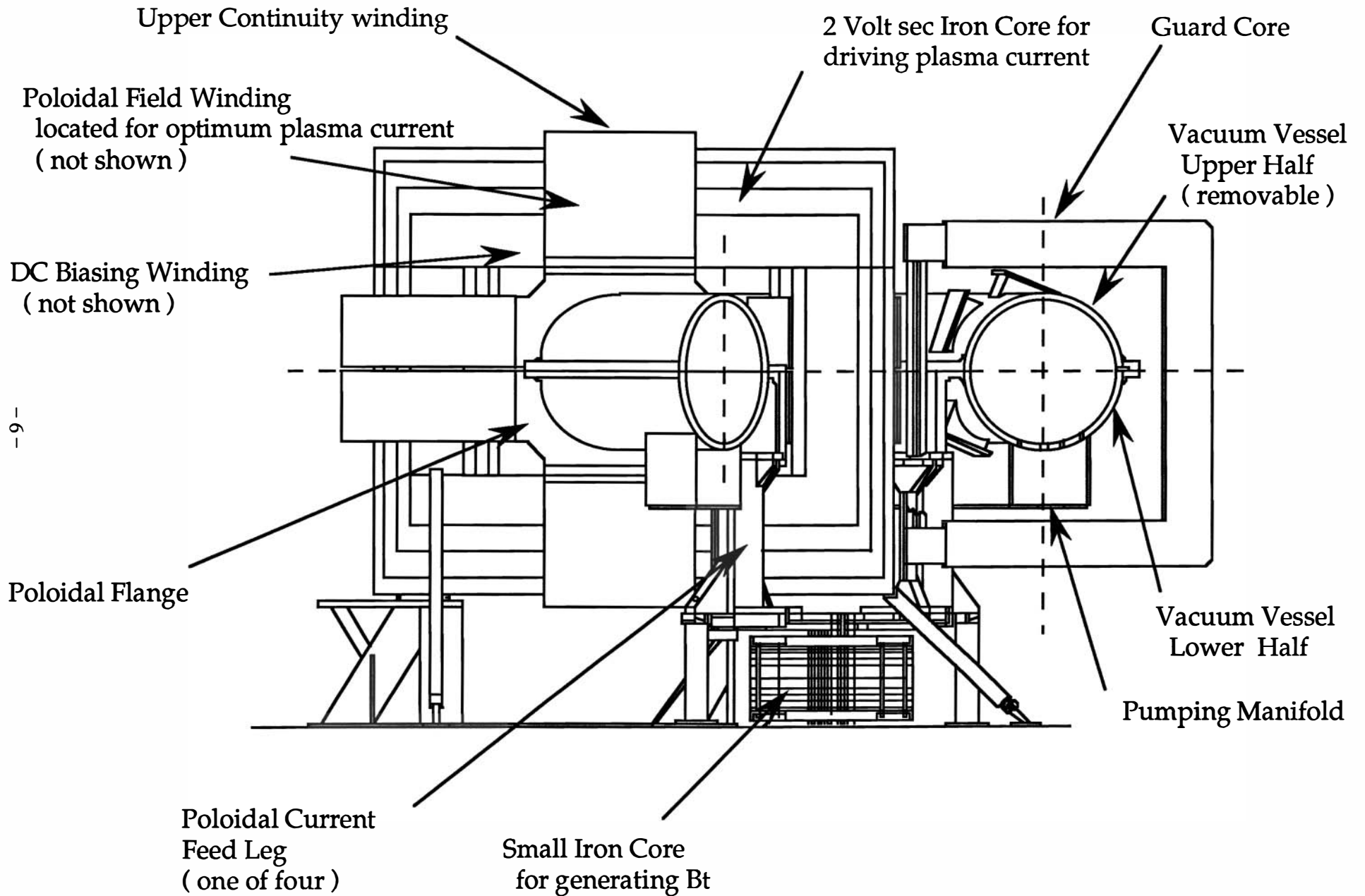

MST Poloidal Field System

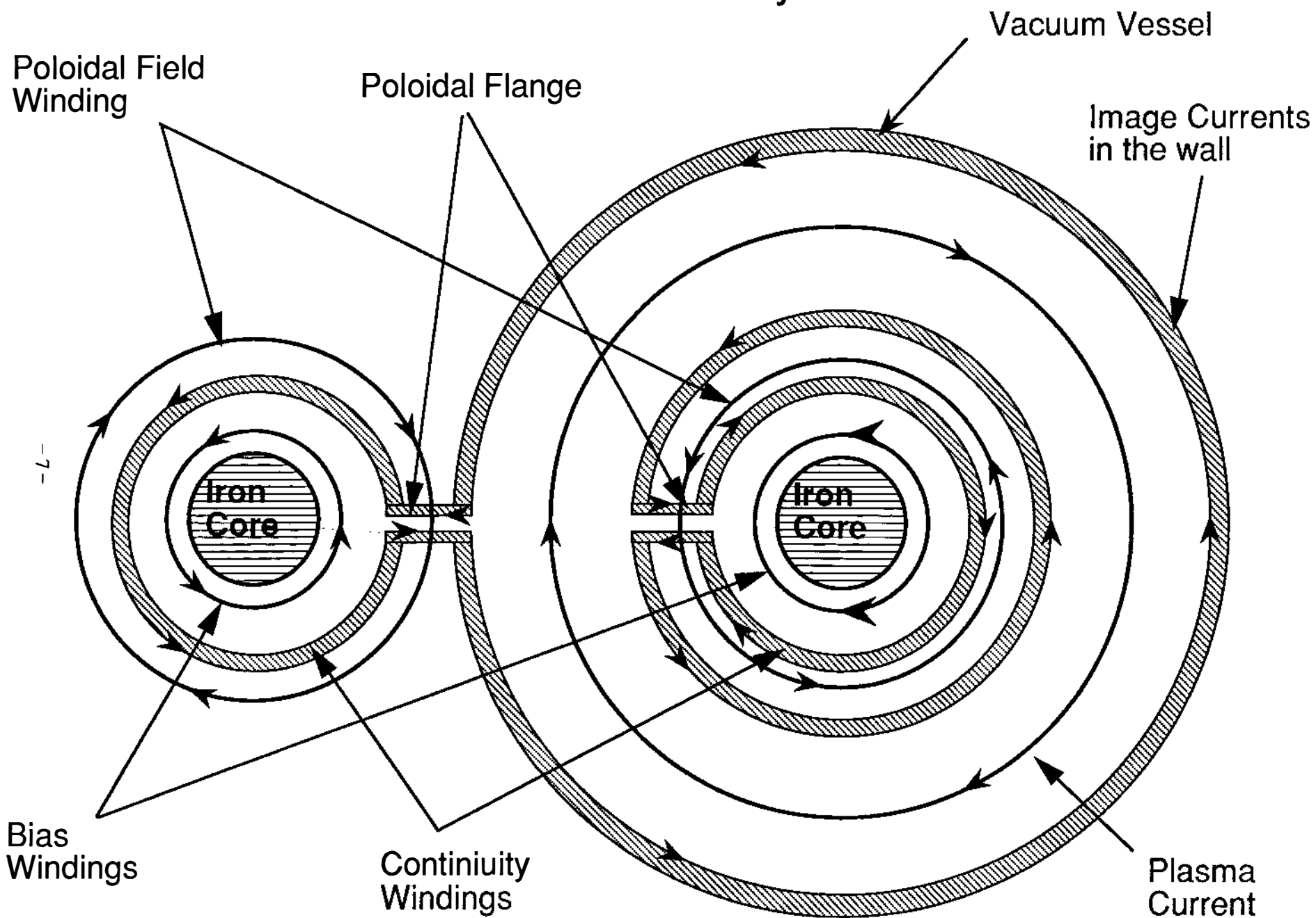

MST Toroidal Field System

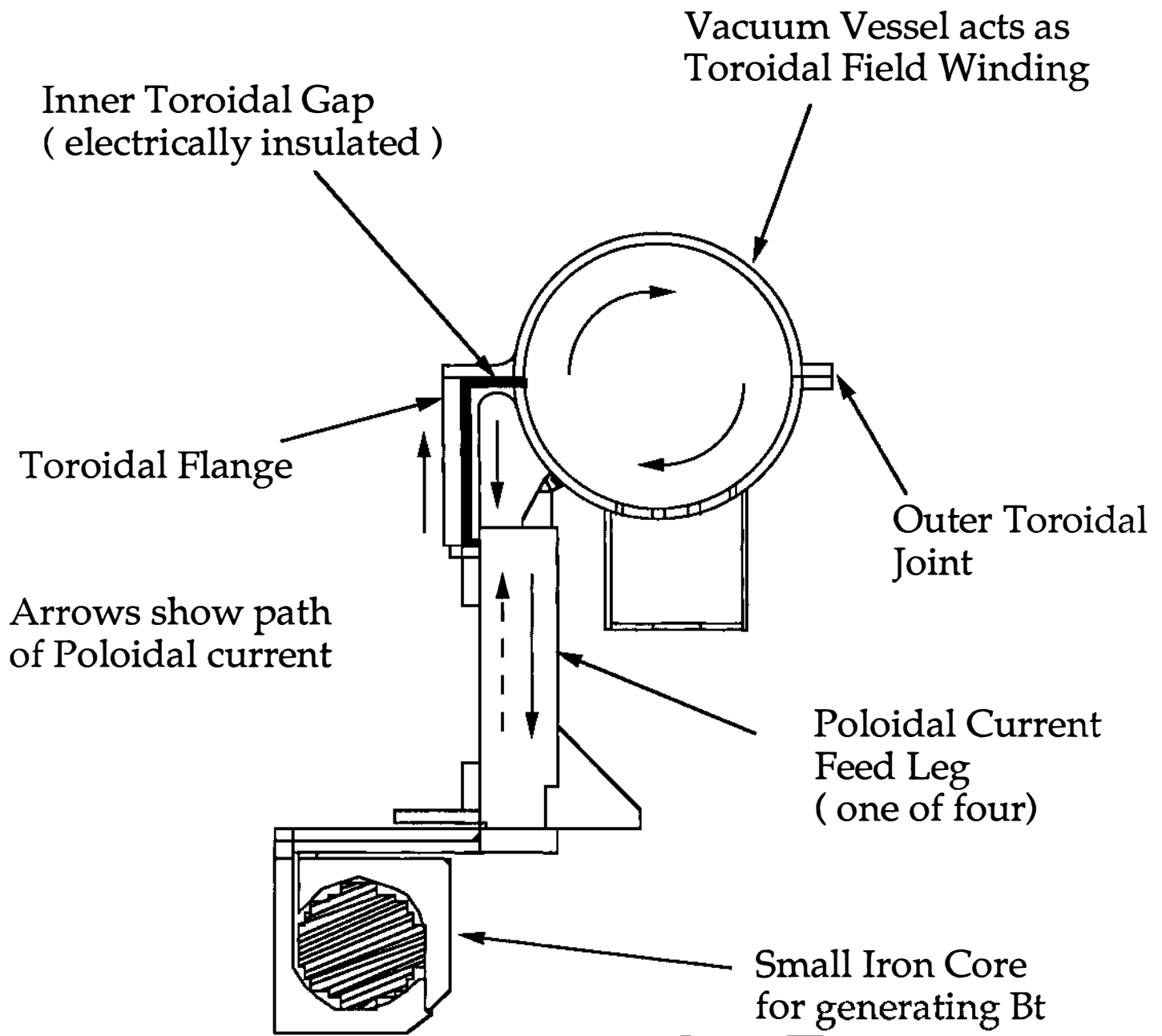

The radial field errors due to the toroidal field system are:

$$B_r (n = 4, m = 0) = 0.2 \%$$

of the toroidal field on axis in vacuum.

(see Almagri, et.al. poster 7V9)

Plasma Current

Shot 84 11-OCT-1988

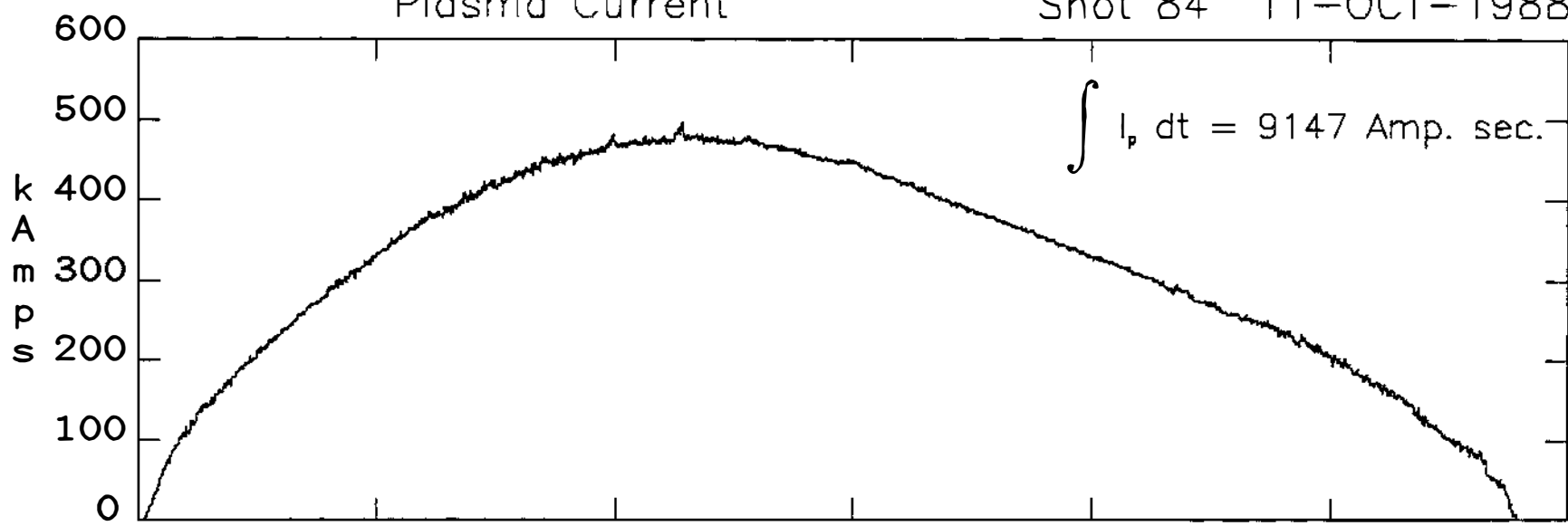

Loop Voltage

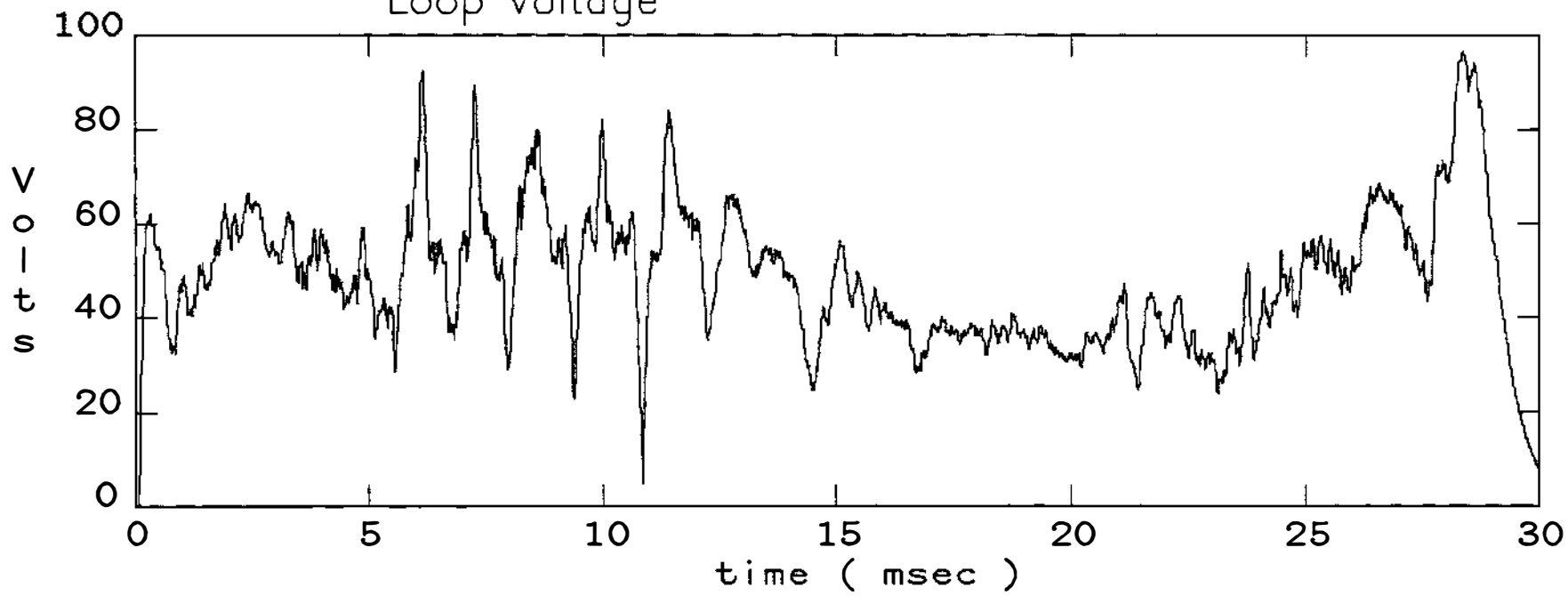

-10-

Physics Goals

Study the effect of the boundary conditions on RFP physics as related to stability, turbulence and transport.

Initially this will be done by varying the vacuum region with a toroidal rail limiter.

q scaling studies from the RFP regime to that of low q Tokamaks.

Support for the next generation RFP's, ZT - H and RFX, by extending the current RFP scaling laws to larger machines.

Plasma Parameters

Predicted

	Pessimistic	Optimistic
Plasma Current	400 kAmps	1 MAmp
Loop Voltage	75 Volts	4 Volts
Ohmic Heating	30 MWatts	4 MWatts
Aver. Tor. Field	1 kGauss	2.5 kGauss
Tor. Field @ wall	-300 kGauss	-150 kGauss
Core Flux	1.8 Volt sec	1.6 Volt sec
Energy confinement	0.4 msec	10 msec
Pulse Duration	10 msec	40 msec

Achieved to date (Oct. 1988)

	Typical Shot	Best to date*
Plasma Current	400 kAmps	0.5 MAmps
Loop Voltage	30 Volts	20 Volts
Pulse Duration	30 msec	35 msec
Reversal Duration	10 msec	20 msec
Reversal Parameter, F	-0.15	-0.6
Pinch Parameter, Theta	1.6	2.1
Electron Density	1 X 10 ¹³ /cm ³	2 X 10 ¹³ /cm ³

* Different shots

Toroidal Field at the Wall Shot 84 11-OCT-1988

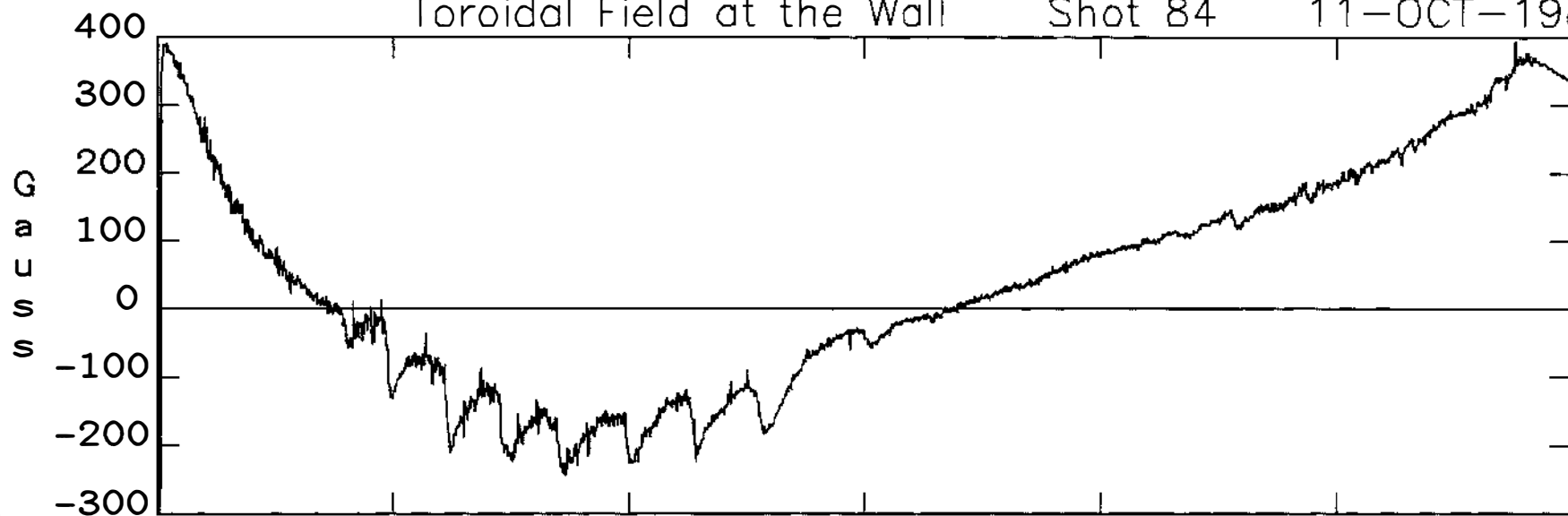

-13-

Average Toroidal Field

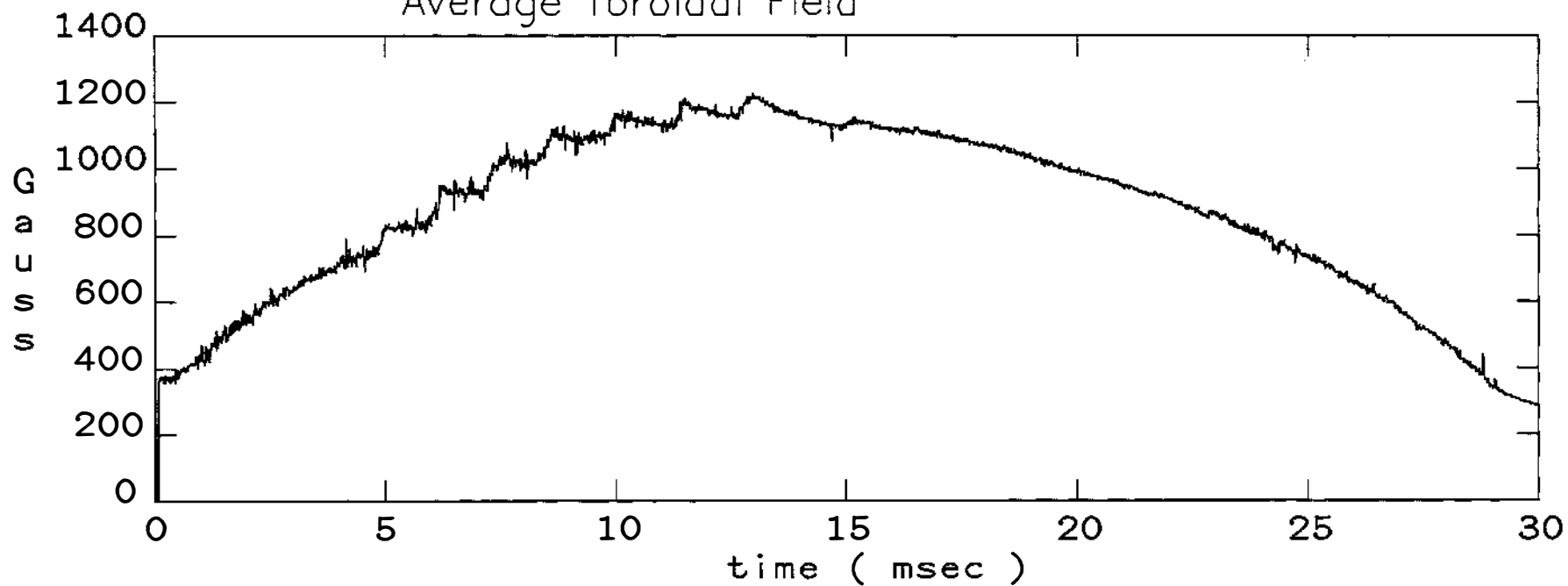

Reversal Parameter, F

Shot 84

11-OCT-1988

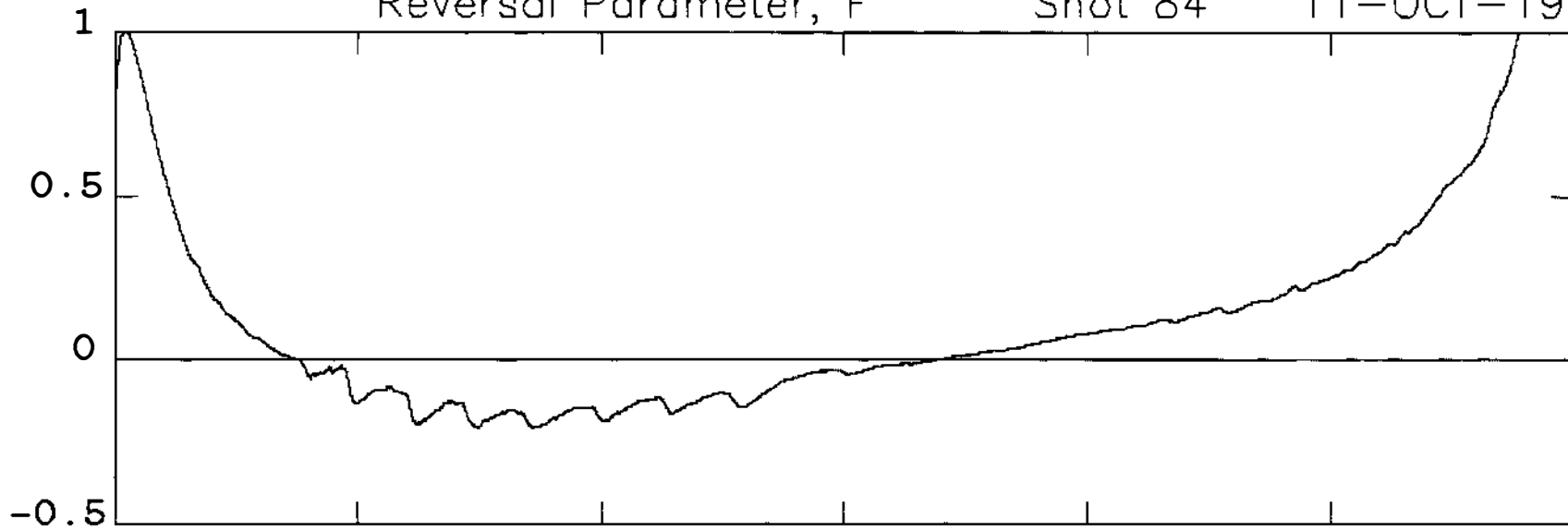

Pinch Parameter, Theta

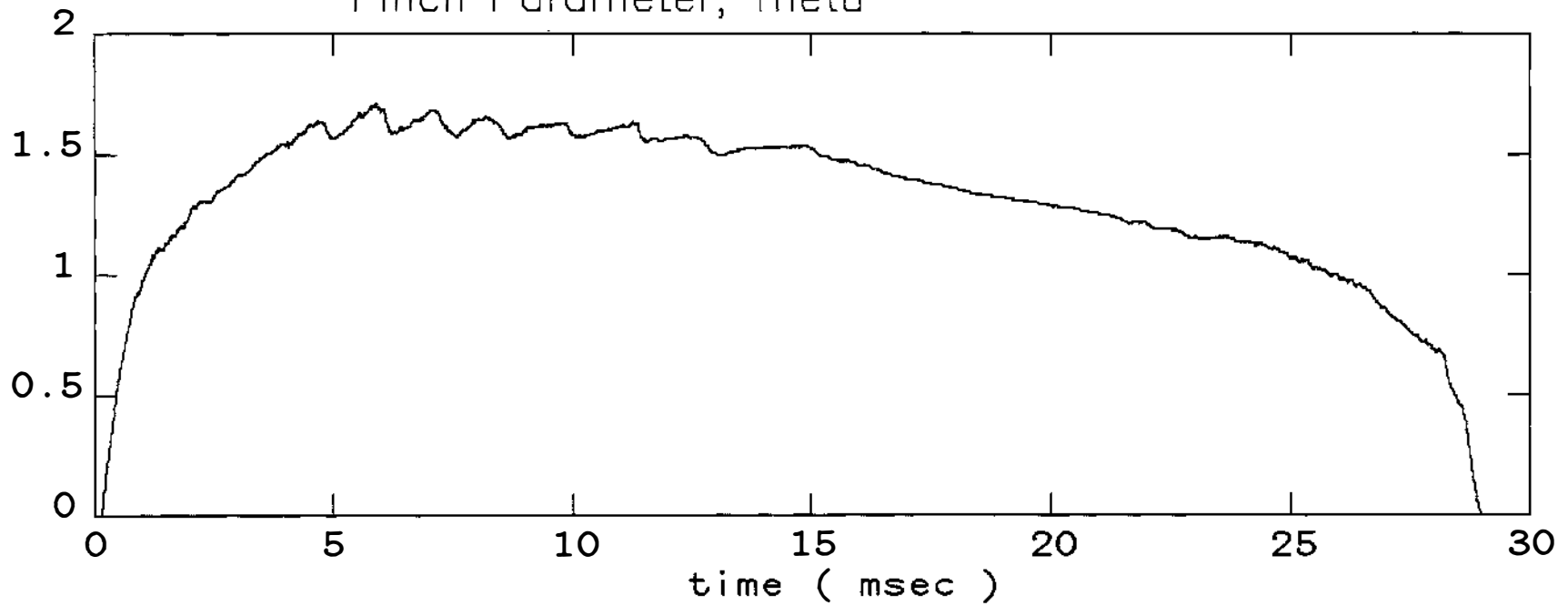

Shot 84 11-OCT-1988

F vs. Theta

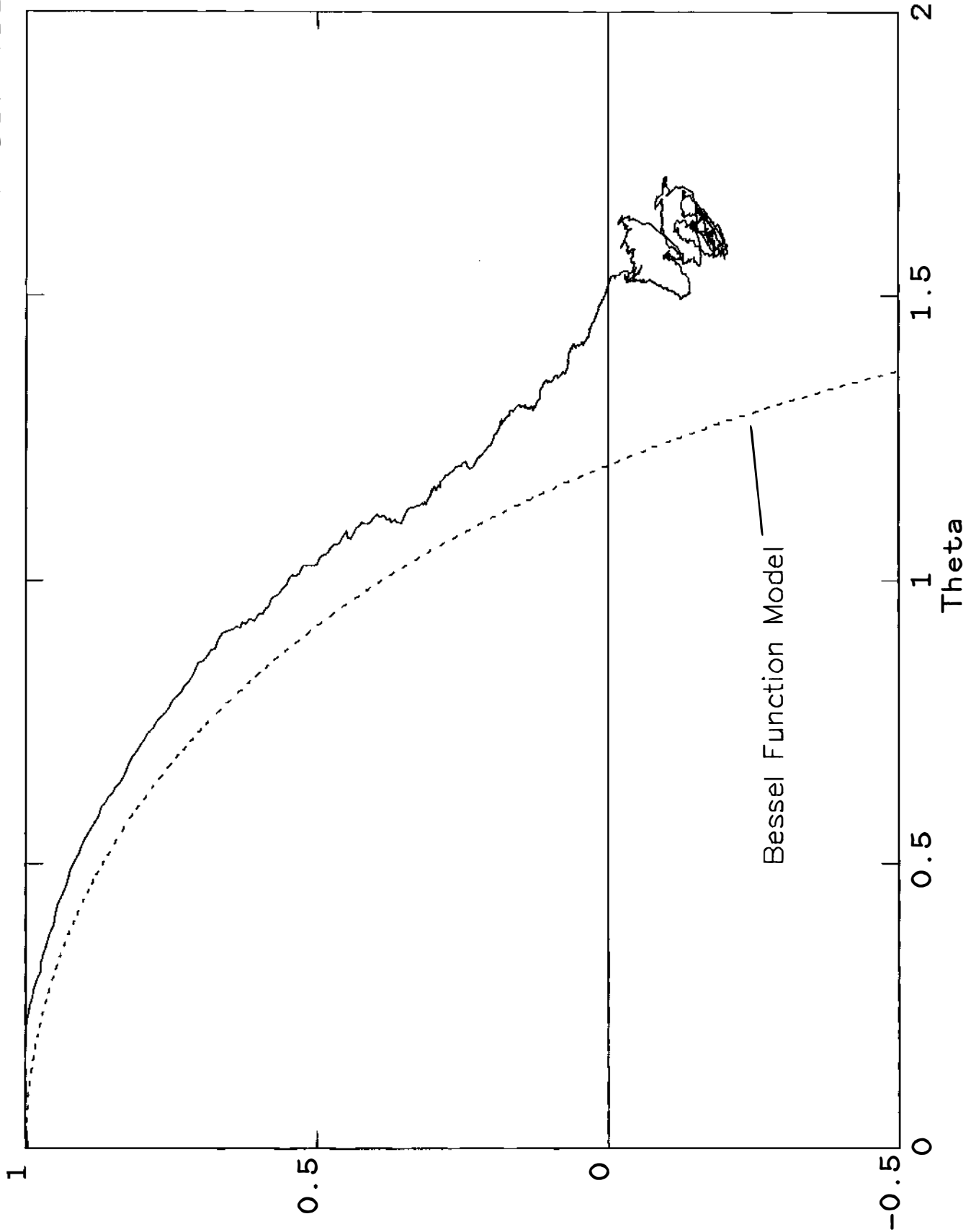

MST is able to operate at a range of F , θ values
at fixed plasma current

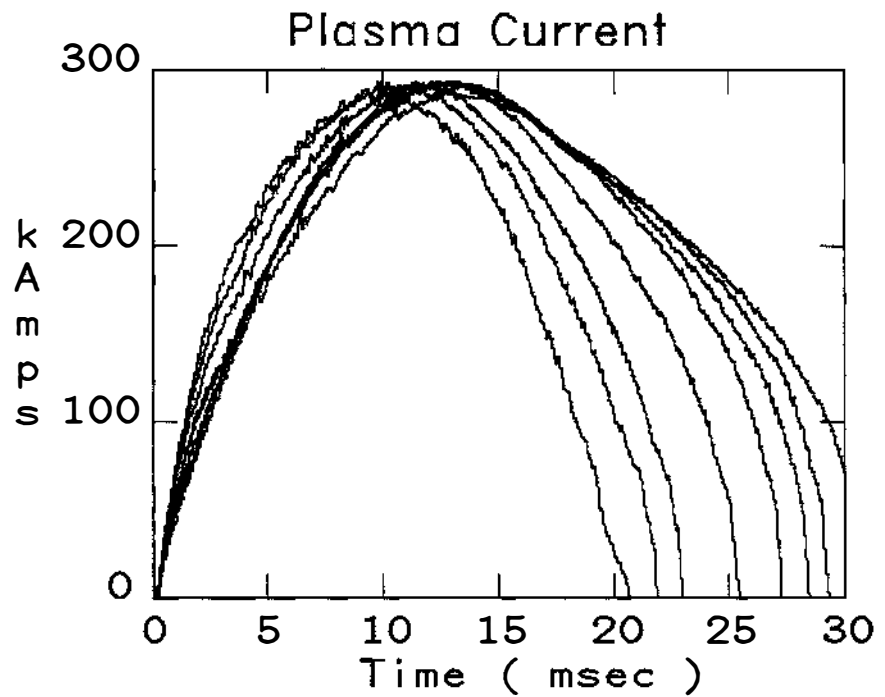
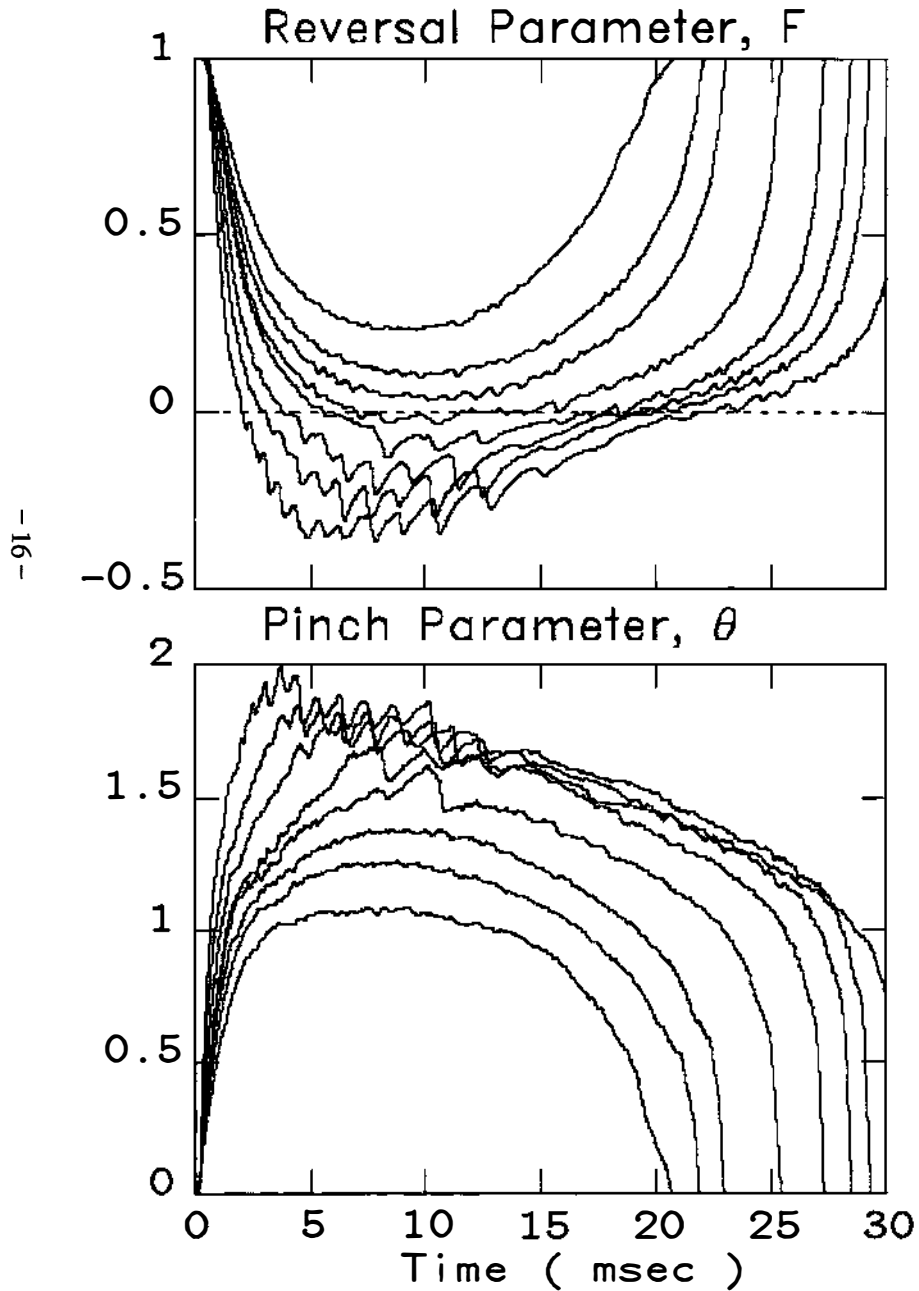

Oxygen lines are burned through early in the discharge
implying a multi-hundred eV temperature

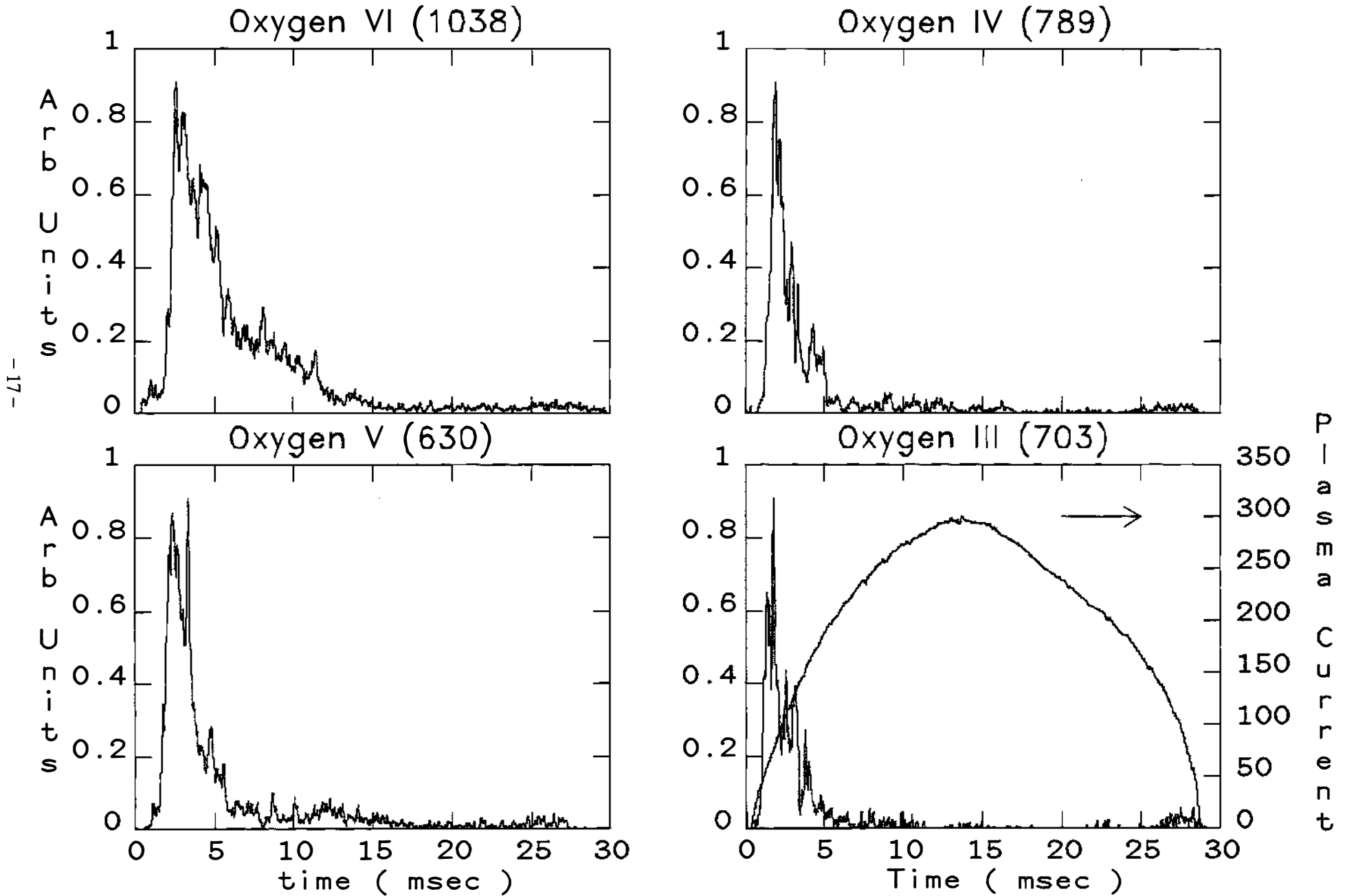

When MST is operated in reversed discharges, sawteeth like oscillations occur in Bt_{wall} and $\langle Bt \rangle$.

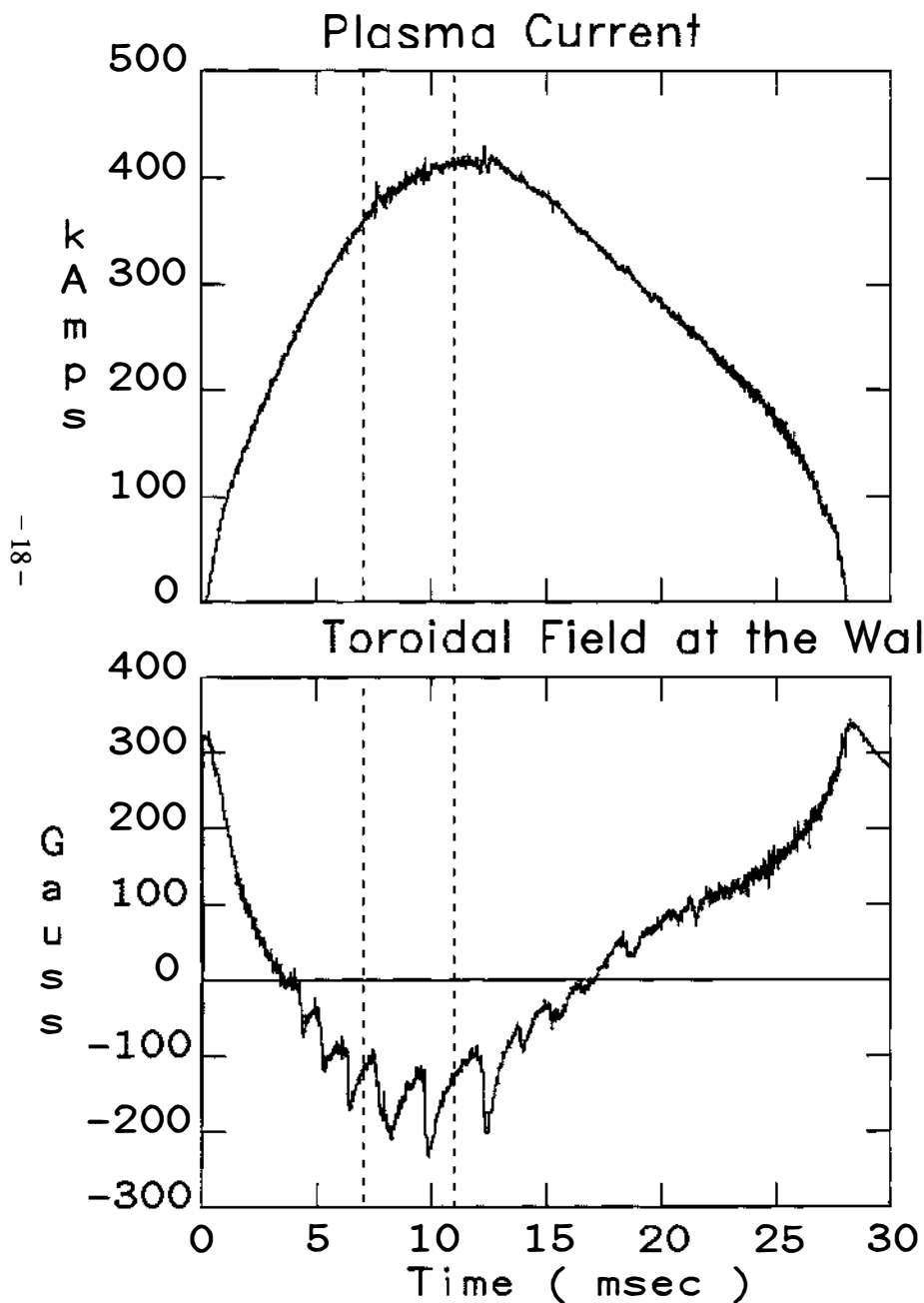

Dotted lines corresponds to the expanded F - Theta graph below

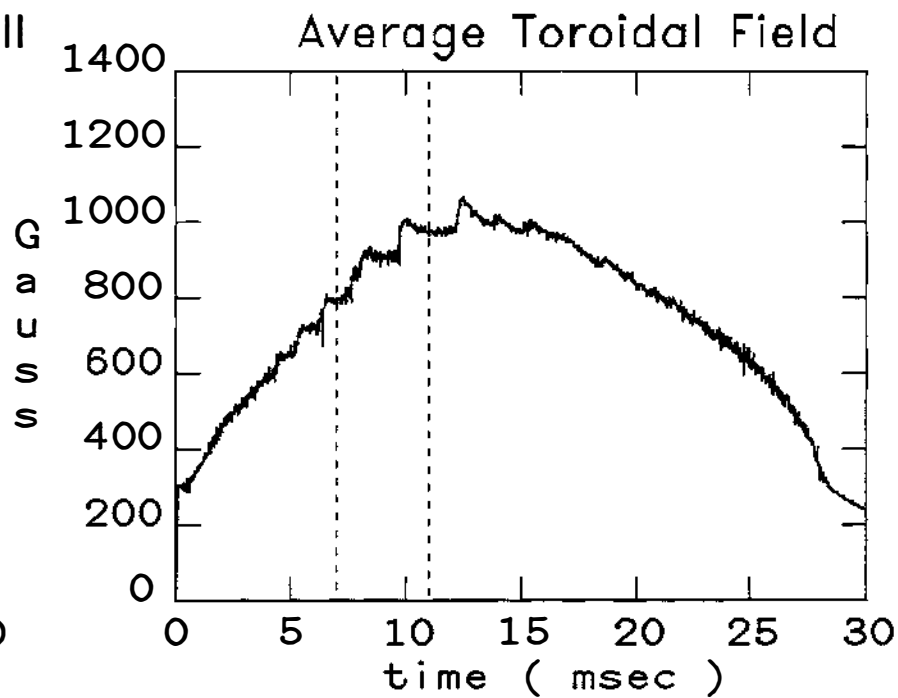

These sawteeth result in increased wall interactions.

Aluminum line 3092

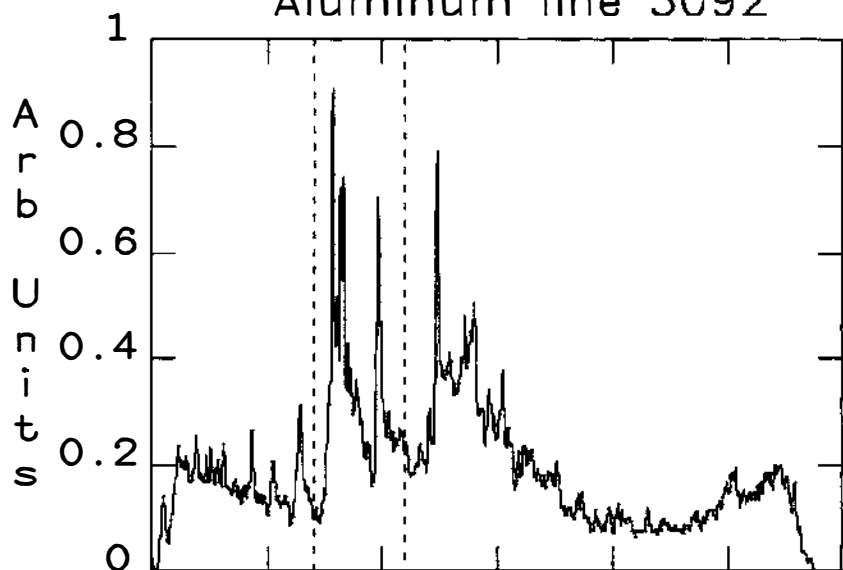

Dotted lines corresponds to the expanded F - Theta graph below

Soft Xray

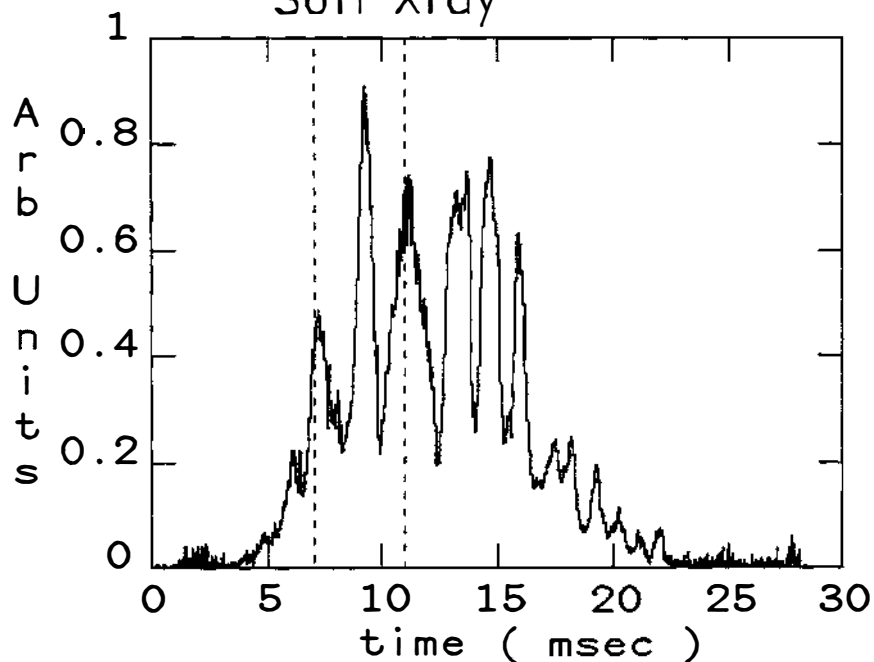

Visible

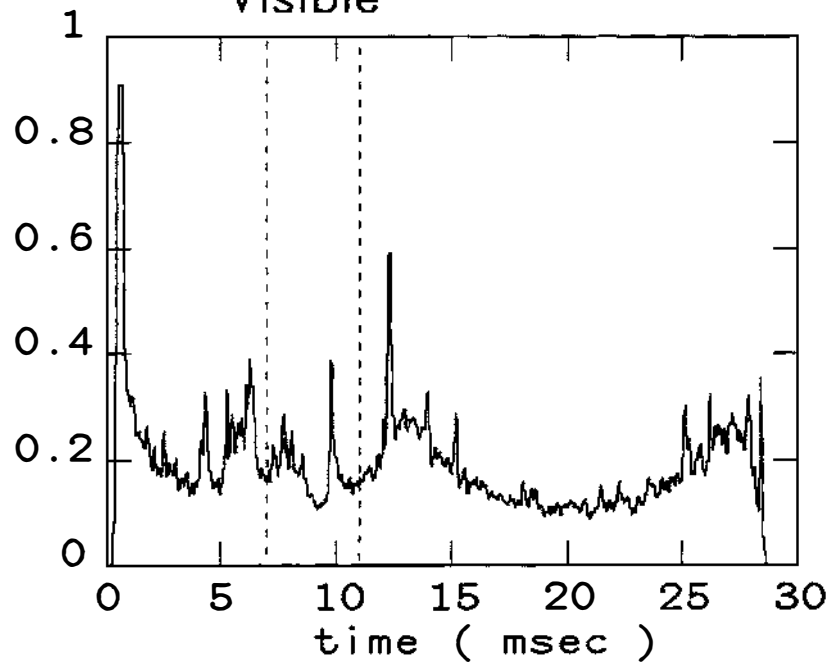

These sawteeth result in $F - \theta$ oscillations.

F vs. θ

Shot 31

20-OCT-1988

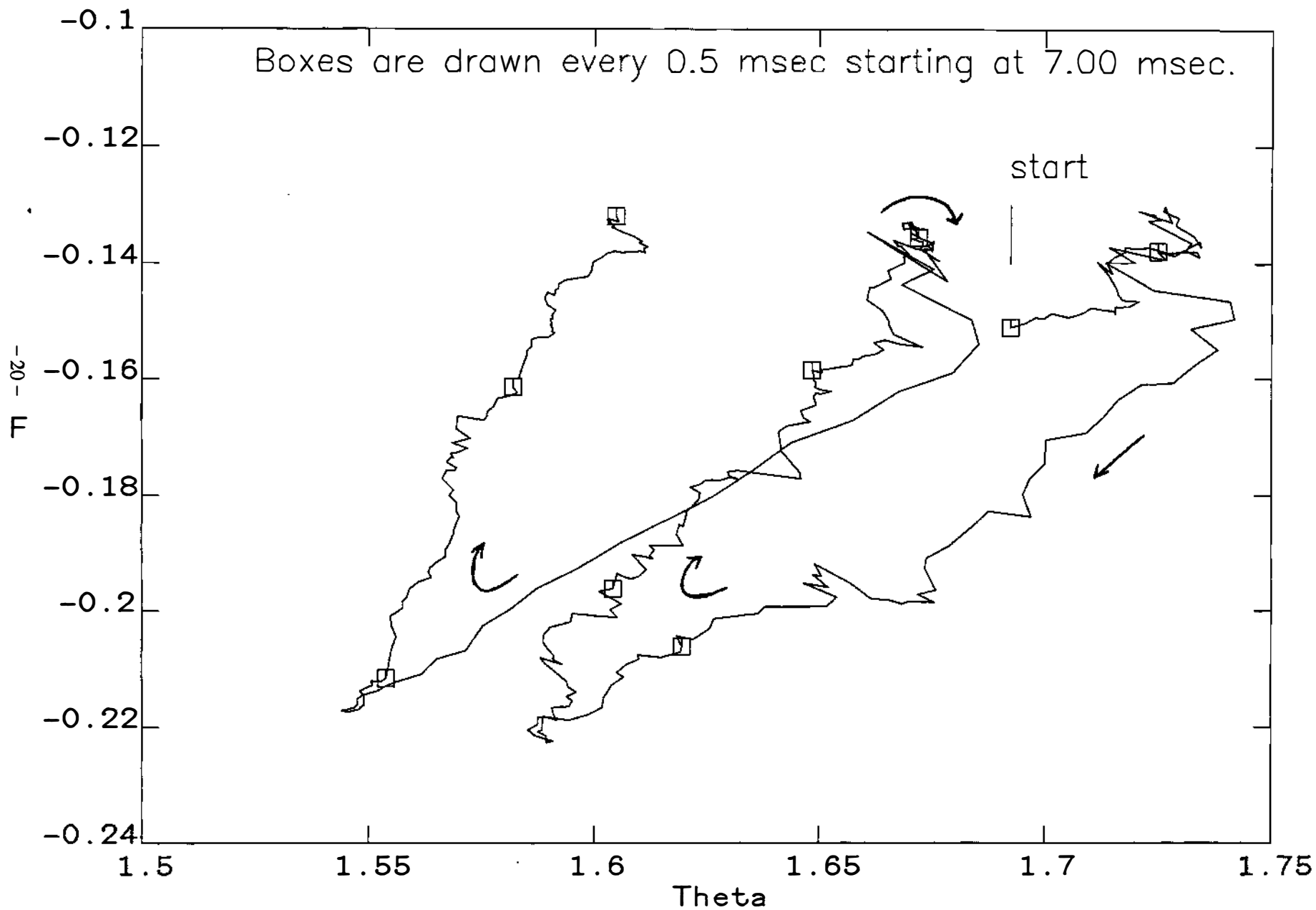

Conclusions and Future Work

Conclusions

The design goals of MST have been met.

Plasmas have been obtained with Plasma Currents of 0.5 MAmps, pulse lengths of 35 msec., and Loop Voltages of 20 Volts.

Field errors due to the toroidal field system are

$$B_r (n = 4, m = 0) = 0.2 \%$$

(see Almagri, et.al, this session 7V9)

Future Machine Modifications

Further wall cleaning is expected with continued operation.

Complete installation of Poloidal Field winding resulting in further reduction of the field errors.

Install a toroidal rail limiter.