

ICRH ON THE SMALL TOROID OCTUPOLE

J. D. Barter and J. C. Sprott

Presented at the November 1975 Meeting

of Division of Plasma Physics

of the American Physical Society

St. Petersburg, Florida

10-14 November 1975

PLP 665

Plasma Studies

University of Wisconsin

These PLP Reports are informal and preliminary and as such may contain errors not yet eliminated. They are for private circulation only and are not to be further transmitted without consent of the authors and major professor.

## ABSTRACT

In view of the encouraging ion heating results previously obtained on the Wisconsin small supported toroidal octupole<sup>1</sup> we have investigated the desirability of extending the heating experiments to the levitated octupole. Using an iterative plasma simulation program tailored to these octupoles we show that the advantages offered by the levitated octupole (larger B fields which can contain higher energy ions, lower background neutrals with less charge exchange loss, and no hoop supports) are offset by the larger machine size. The larger size (a factor of 3 in linear dimensions) lowers the obtainable rf electric field by 3 and the cyclotron heating by 9. A pulse forming network and oscillator system are being developed to extend the previous 500 kw, 1 msec rf capability to ~ 1 MWatt, 2 msec. In conjunction with increased field capabilities in the small octupole we hope to produce ion temperatures approaching 300 eV as predicted in the simulation program.

A cross section of the supported toroidal octupole is shown in Fig. 1. The toroidal axis is to the left. The four poloidal field current hoops are driven inductively with a 10 ms half sine period to produce an octupole field with a null field region near the minor axis. The field at the outer wall is  $\approx 2.2$  kG and near an inner hoop the field is  $\approx 14$  kG. (Bank charge voltage  $\leq 5$  kv). Surfaces of constant poloidal field (cyclotron resonance surfaces) form toroidal surfaces of approximately circular cross section about the minor axis.

The ion energy distributions are measured with an electrostatic curved plate analyzer which extracts ions from the null field region through a ferromagnetic  $\mu$  pipe.

The fifth hoop which couples power to the plasma is coaxial to the four main hoops and located 1 inch above the floor. A faraday shield and stainless limiter are used to keep electrostatic fields out of the plasma. The hoop has a gap which is driven externally. The hoop thus forms the inductive leg of an oscillator tank circuit as shown in Fig. 2. This arrangement allows the oscillator to track in frequency in the presence of reactive plasma loading.

The fifth hoop inductance is  $.7\mu\text{H}$ . The tank circuit can be tuned from 1 to 3 MHz with a parallel resistance of 340-1.5 k $\Omega$  over this range. The added plasma load (in parallel) is  $\sim 6$  k $\Omega$  for  $n = 10^{11}\text{cm}^{-3}$ .

The oscillator is a triode designed to accept -20 kv for 2 ms and to supply up to 1 Mwatt to the tank circuit. These design limits have not been realized yet because the fifth hoop arcs inside the vacuum.

The induced toroidal field of the fifth hoop is measured directly above the hoop in the mid cylinder (see Fig. 1) and is plotted in Fig. 3.

The electric field is normalized to the field at the hoop surface. The field was measured without plasma (triangles) and again in the presence of a  $6.7 \times 10^{12} \text{ cm}^{-3}$  plasma and shows good penetration at least as far as the resonance zone. The solid curve represents a simple theoretical prediction for the field based on the major image currents in the tank floor and lid.

Note that the field falls off rapidly away from the hoop. This leads to a compromise for best ion heating. The resonance zone is chosen to give the highest electric field possible without scraping large gyroradius ions off on the limiter.

Fig. 4 shows a "representative" heated ion distribution as obtained with our previous oscillator and encouraging us to build the higher power system.

The graph shows a two temperature maxwellian. About 50% of the particles are heated which is consistent with the fraction of particles that don't cross the resonance zone near the fifth hoop due to mirror trapping. No deleterious effects are observed other than increased obstacle losses and charge exchange losses due to the increased  $T_i$ . An increased neutral density is also observed due to wall reflux.

The temperature of the heated component has been measured as a function of the volts applied to the fifth hoop and the results are plotted in Fig. 5. The experimental data is indicated with error bars. The uncertainty at low temperatures is due largely to the finite resolution of the analyzer which is  $\sim 2-3$  eV. The data is compared to a computer simulation of the plasma (the solid line) which uses average values for machine size, densities and gradients to calculate average values for thermal heating and cooling, and particle production and loss mechanisms as a function of time. The ion cyclotron resonance heating is based on single particle, cold plasma theory. Suppression of the electric field has been

neglected as previously justified.

Note - that if the experiment continues to scale with the simulation we may hope to produce 400 eV temperatures at the design limits of the oscillator of 18.5 kV<sub>op</sub> applied to the hoop.

The temperature has also been measured as a function of the H<sub>2</sub> filling pressure and is plotted in Fig. 6. Again the simulation is the solid line, the experiment is indicated with error bars. The agreement is good except at the highest powers where the plasma density is low, the hoop voltage may have been high (lightly loaded), and the ion cooling terms in the simulation are unreliable.

These experiments have been done on the small supported octupole. It has been suggested that the large levitated octupole, also at Wisconsin, might provide higher ion temperatures because of its better containment. The simulation has been adapted to this case for a fifth hoop of the same design but scaled up in size. Under the restriction that we use the same applied voltages as available to the small machine the resulting temperatures are about the same. This can be explained by considering the larger size of the machine which reduces the electric field in the plasma by ~ 3. The power applied to a similar density plasma is thus reduced by nearly a factor of 10.

In view of this fact and the ease and economy of working on the small octupole, ion heating will probably not be attempted on the levitated octupole in the immediate future.

REFERENCES

1. J. D. Barter and J. C. Sprott, Phys. Rev. Letters 34, 1607 (1975).

FIGURE CAPTIONS

1. Cross section of the toroidal octupole showing the fifth hoop (shielding and limiter not shown) and electrostatic ion energy analyzer.
2. The 1 MWatt oscillator circuit with fifth hoop forming the inductance of the tank circuit.
3. The normalized electric field with and without plasma measured directly above the hoop (in the midcylinder).
4. A heated ion distribution function as measured by the electrostatic analyzer sampling ions from the field free region of the octupole.
5.  $T_i$  vs  $V_{op}$  the zero to peak volts applied to the terminals of the fifth hoop. Error bars show experimental data, the solid line indicates the results of program SIMULT.
6.  $T_i$  vs  $H_2$  filling pressure. Error bars show data, the solid line is the simulation.

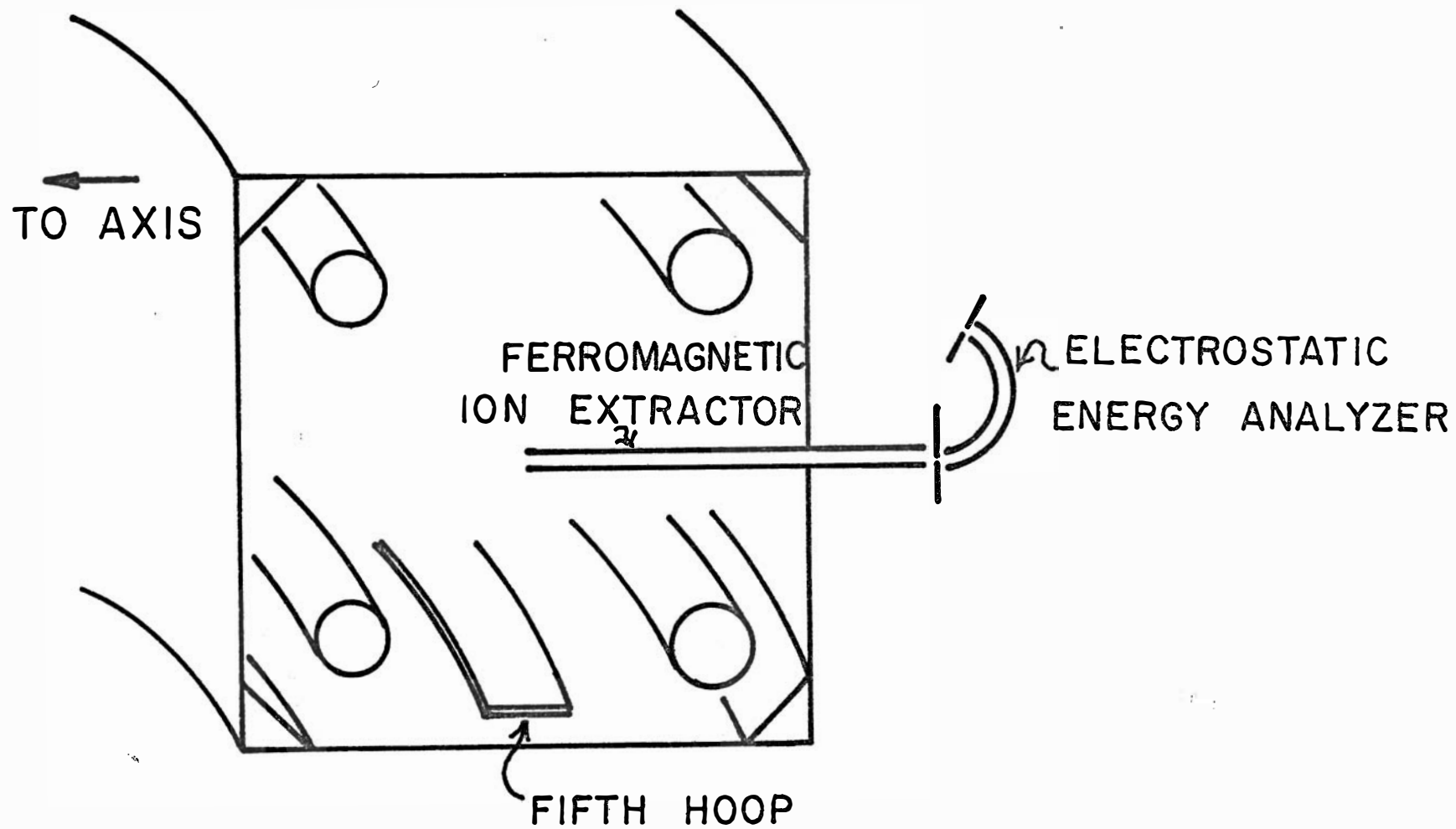

Fig 1



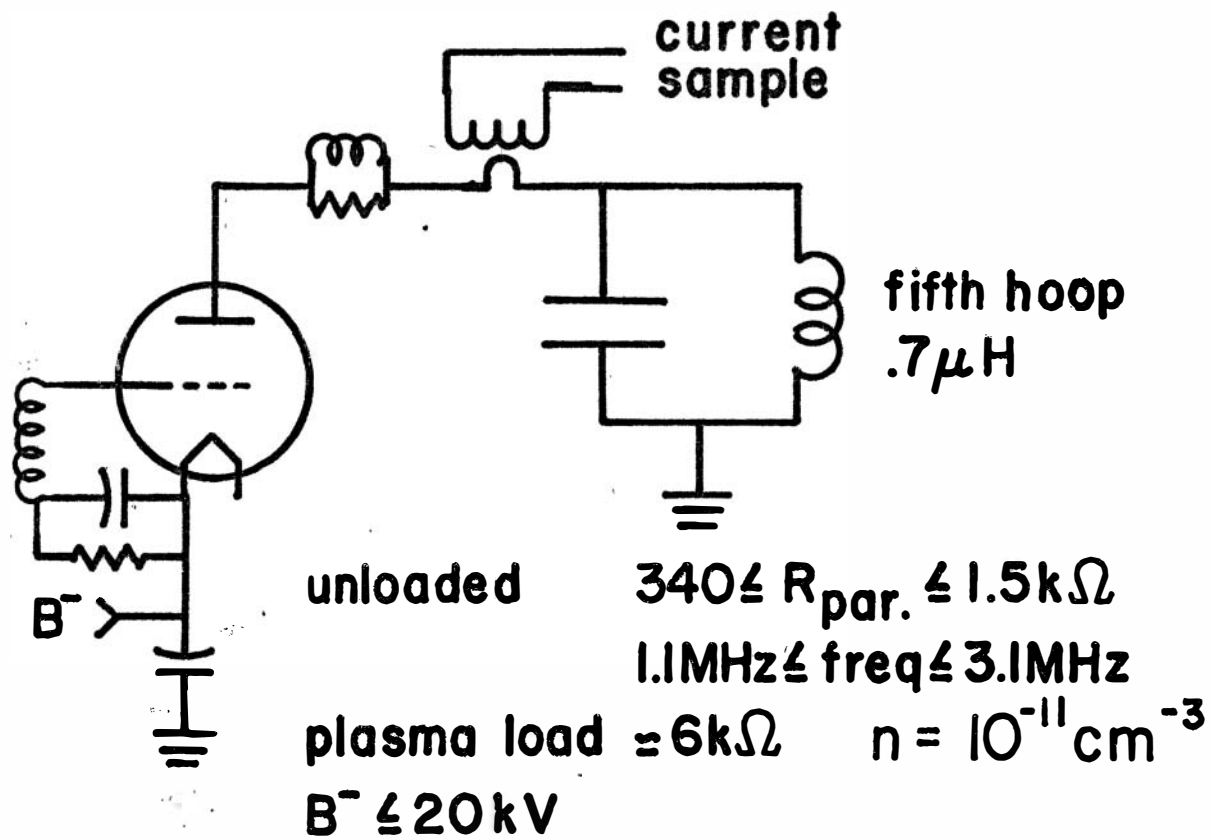
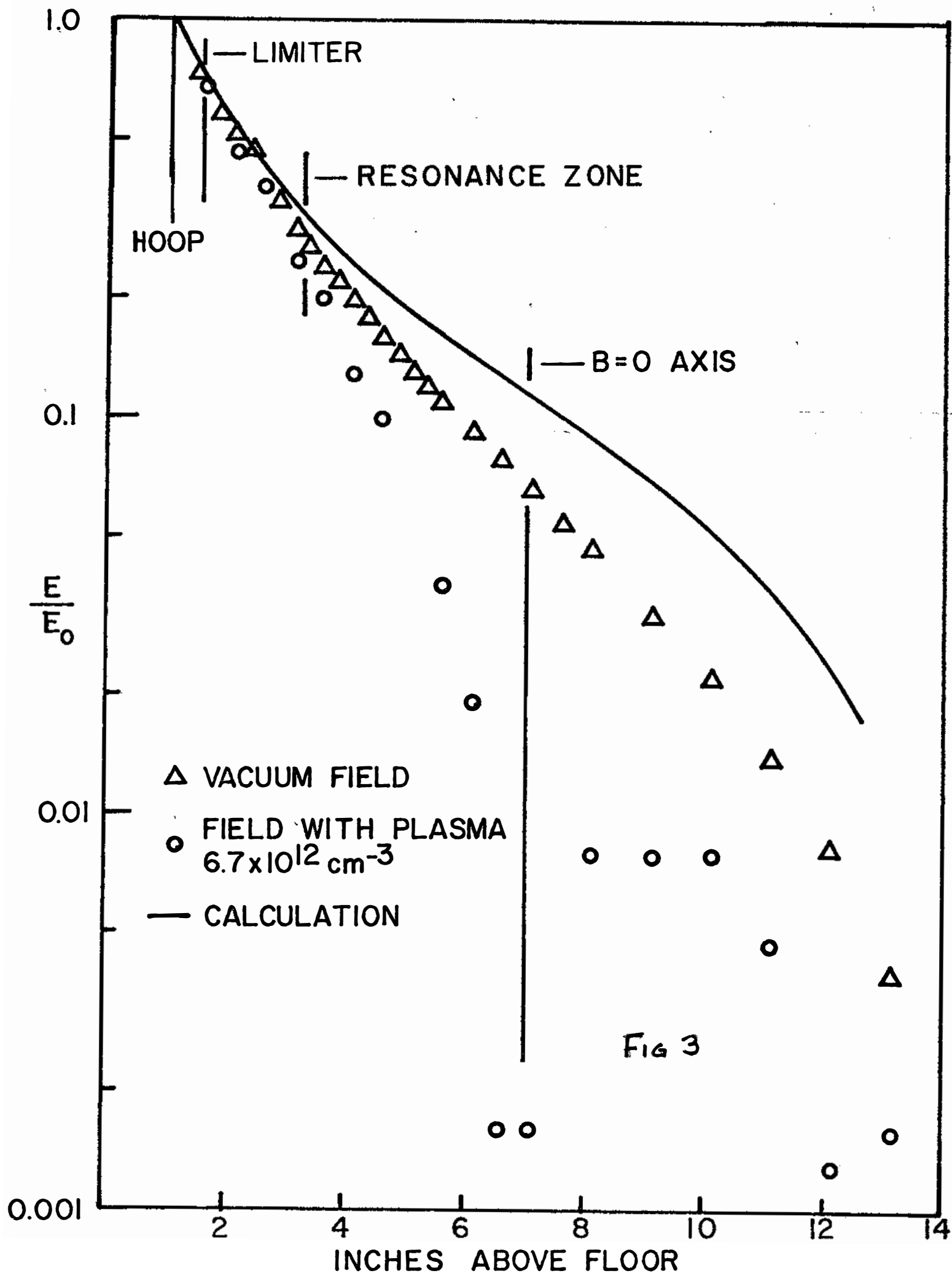
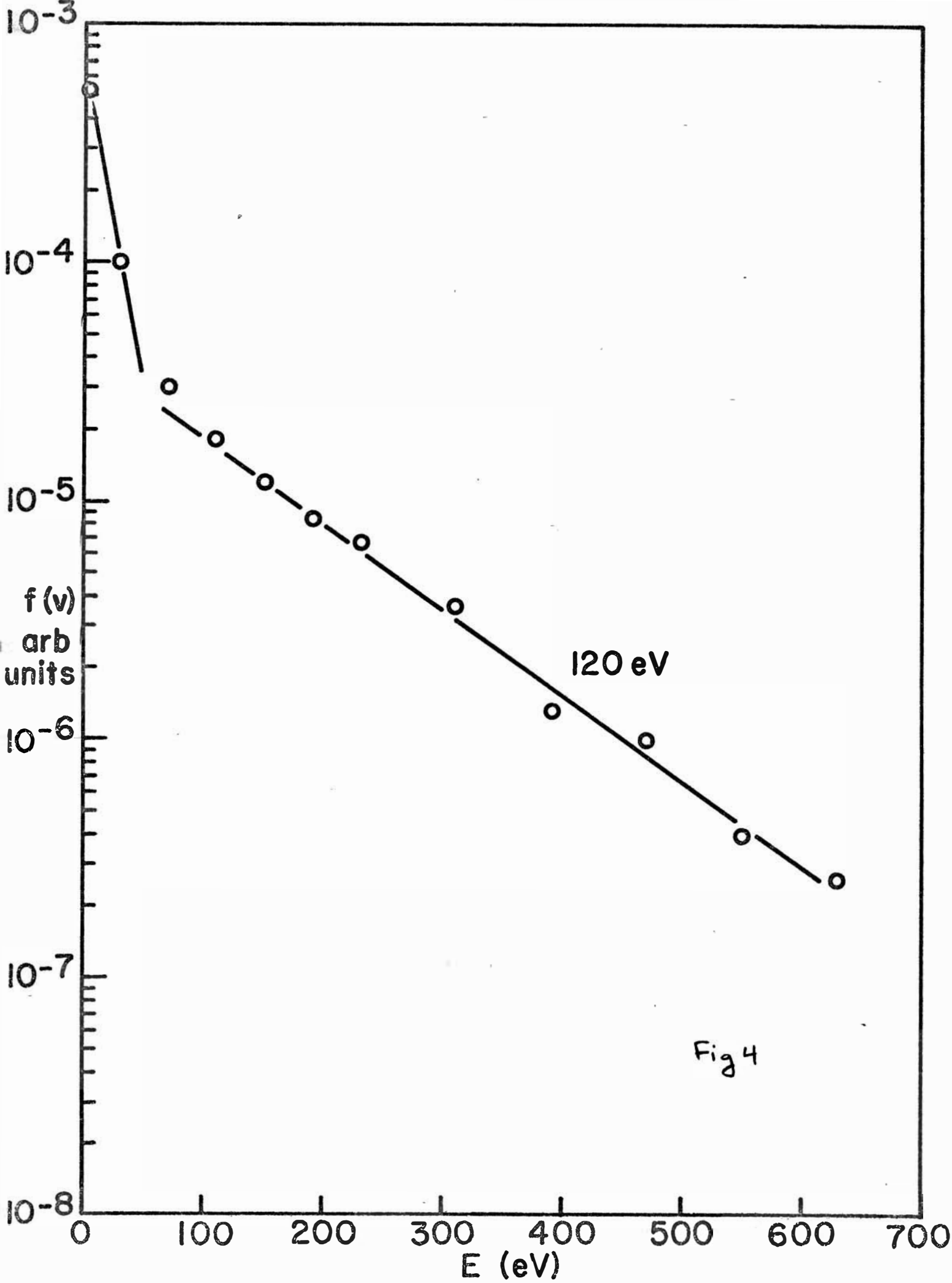

Fig 2





$T_i$  vs  $V_{op}$

1000

100

$T_i$   
(ev)

10

1

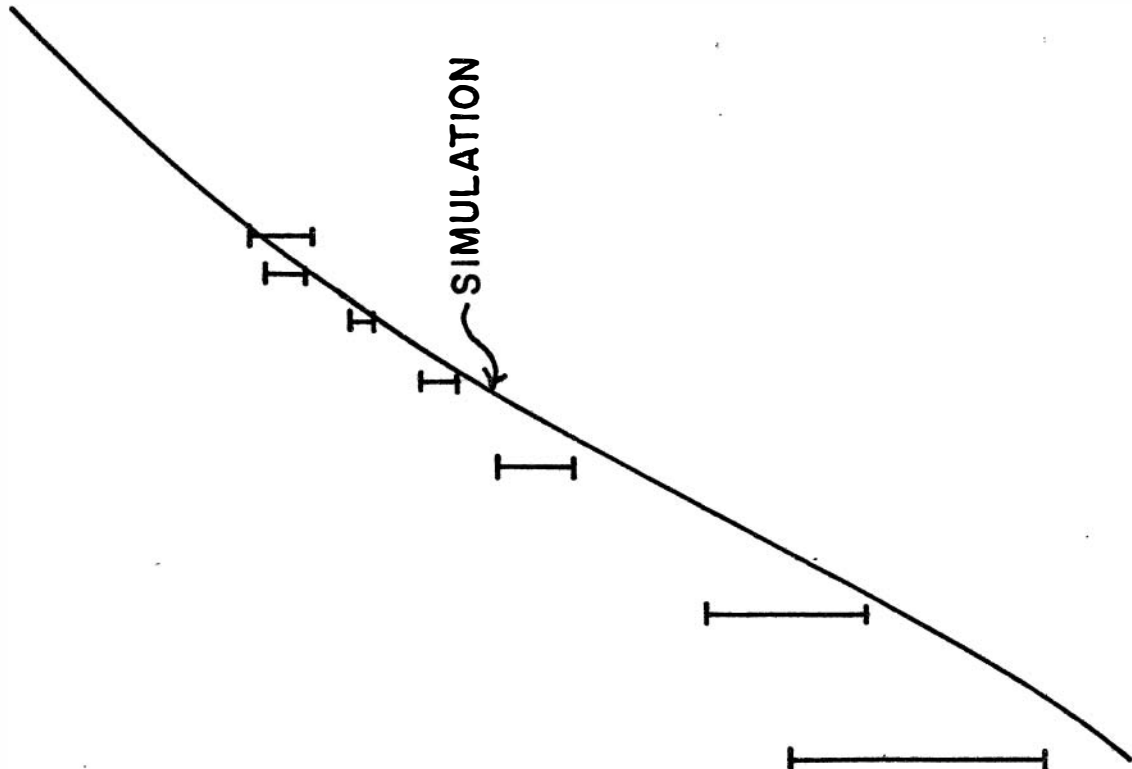

Fig 5

$T_i$  vs  $n_0$

1000

$T_i$   
(ev)

100

10  
 $10^{11}$

$10^{12}$

$n_0$  ( $\text{cm}^{-3}$ )

$10^{13}$

$10^{14}$

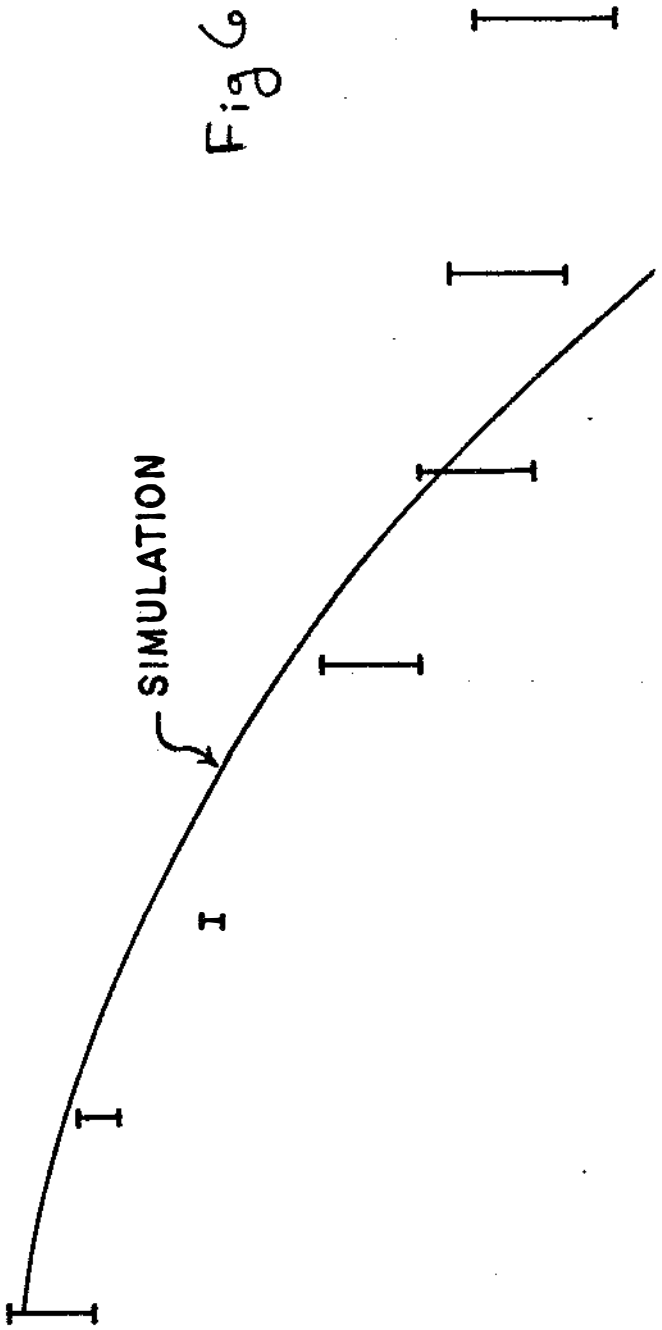

Fig 6