

SECOND RESULTS FROM THE WISCONSIN NON-CIRCULAR RFP

J.C. Sprott

PLP 978

May 1986

Plasma Studies

University of Wisconsin

These PLP Reports are informal and preliminary and as such may contain errors not yet eliminated. They are for private circulation only and are not to be further transmitted without consent of the authors and major professor.

## SECOND RESULTS FROM THE WISCONSIN NON-CIRCULAR RFP

by J.C. Sprott

Included here are copies of the posters presented at the 1986 IEEE International Conference on Plasma Science in Saskatoon, Canada, May 19-21, 1986. (Ref: IEEE Catalog No. 86CH2317-6, page 79, 1986). The data represent more recent and non-overlapping results than those presented in PLP 969. The major new results are the extension of the 200 kA/8 msec discharges to 300 kA/10 msec and estimates of the plasma density, temperature, and confinement time. The changes were brought about by operation at higher poloidal bank voltages (4400 volts vs 3500 volts), core biasing, correction of some field errors at the poloidal gap, improved vacuum conditions, and better control of the gas puffing.

Some improvements in plasma parameters have been obtained, but there is still no evidence of a quiet period when the field reverses, and the resistivity is still 5-10 times the ZT-40 value at the same plasma current. Reduction of some known large field errors at the poloidal gap did not lower the resistivity. The most likely cause is the influx of impurities as evidenced by a rising resistivity and density, and a rising level of oxygen and aluminum radiation during the pulse. The discharges continue to show slow improvement with surface cleanliness and are easily spoiled by vacuum accidents.

Interferometer measurements indicate a typical line-averaged density of  $5 \times 10^{12} \text{ cm}^{-3}$ , which is consistent with the fill pressure of  $\sim 0.2$  mtorr (gauge). Measurements of the oxygen line radiation, Doppler broadening of

carbon III, and the neutral charge exchange spectrum suggest a peak temperature of  $T_e \sim T_i \sim 100$  eV, which implies  $Z_{\text{eff}} \sim 5$ . For a plasma current of 300 kA, a loop voltage of 60 volts and a volume of  $8.6 \text{ m}^3$ , these numbers correspond to an energy confinement time of

$$\tau_E = \frac{1.5 \langle n \rangle k (T_i + T_e) V}{I_p V_d} \sim 100 \text{ } \mu\text{sec} .$$

This estimate may be low because it comes from data at the time of peak current which is near the end of the discharge after a significant impurity influx has occurred.

Near-term plans call for installation of stainless, toroidal limiters in May '86, installation of divertor rings in July '86, and installation of the Thomson scattering system in September '86. The installation of the new MST vacuum vessel is scheduled for April '87, with first RFP plasmas expected in October of '87.

## ABSTRACT

By removing the internal rings from the Levitated Octupole vacuum vessel, a large, non-circular RFP was produced. The major radius is 1.39 m, and the cross section is about  $1 \text{ m}^2$ . The device is unconventional in that the vacuum vessel, which consists of 5-cm thick aluminum with a single poloidal and toroidal gap, serves as the vacuum liner, conducting shell, and poloidal and toroidal field coils. A toroidal field of up to about 1 kG can be produced, and the poloidal field is driven by a 600 kJ capacitor bank through a 2-volt-second iron core. Discharges are initiated with  $\leq 200$  volts per turn using self-reversal of the toroidal field in order to prevent arcing of the poloidal gap which is exposed to the plasma. The gap is protected with a 20-cm wide strip of ceramic.

The best RFP discharges have a peak current of  $\sim 200$  kA and a duration of  $\sim 10$  msec. The toroidal field reverses when the current reaches  $\sim 100$  kA, making this one of the lowest current density RFP's in existence. The current ramps up to the final value over  $\geq 10$  resistive diffusion times and terminates only because the volt-second limit of the iron core is reached. The  $F-\theta$  trajectory lies slightly to the right of the  $\lambda=\text{constant}$  theory as do all other RFP devices. Discharges have been produced with  $\theta$  up to 2.5 and  $F$  as low as  $-0.8$ .

A feature of the device is that it is capable of producing discharges with plasma current of  $\geq 100$  kA and  $\geq 10$  msec duration over a wide range of safety factor from the  $q > 1$  tokamak limit to the deeply-reversed, RFP limit. The highest current discharges ( $\sim 300$  kA) are obtained at  $q \sim 0.5$ .

The plasma noncircularity (indented at the midplane) provides an opportunity to gain experimental information on whether fluctuations in an RFP are current-driven or pressure-driven instabilities generated by unfavorable poloidal curvature. To this end, we are measuring the edge magnetic fluctuations in the separate good and bad curvature regions on a given magnetic surface. Results will be presented for both reversed and non-reversed discharges (at various q values).

The resistivity of the RFP discharges is lower than non-reversed discharges but a factor of 10 higher than other RFP's with the same current. The resistivity correlates strongly with vacuum conditions, indicating a need for more aggressive cleaning and impurity control. The time-dependence of the plasma electrical parameters agrees with a simple electrical circuit model in which the plasma resistivity is given for all times by  $R_p = \text{const}/I_p$  where the constant is typically 50-100 volts and depends on the surface cleanliness.

Plans call for improving the cleanliness of the machine, improving the electrical circuits and measuring the density and temperature. Over the longer term, new internal rings will be installed to attempt RFP operation with a magnetic limiter (or poloidal divertor). Thereafter, the vacuum vessel will be replaced with a new circular vessel with  $R = 1.5$  m and  $a = 0.52$  m. The new device, called MST, is scheduled for completion in late 1987.

5) The plasma resistance drops, and the conductivity temperature rises when the plasma enters the reversed-field state. However, there is no noticeable quiet period, and the resistivity is still an order of magnitude higher than in ZT-40. The conductivity temperature strongly correlates with vacuum conditions, indicating a need for more aggressive discharge cleaning. Removal pumping rate per unit wall surface area is quite low ( $\sim 1000\ell/\text{sec}/40\text{m}^2$ ).

6) Numerical circuit modeling using the experimentally observed F- $\theta$  curve and a plasma resistance of  $R_p = 65/I_\phi$  at all times produces a remarkably accurate prediction of the plasma electrical waveforms. If the plasma resistivity can be lowered to the ZT-40 value, small improvements in the electrical circuits should allow 500 kA/20 msec RFP discharges.

7) Temperature and density (and hence confinement time) have not yet been measured. The conductivity temperature never exceeds 20 eV, but shows improvement with surface cleanliness. Density is apparently low as evidenced by the optimum  $\text{H}_2$  fill pressure of  $\sim 0.1$  millitorr. The ability to start up at low pressure is greatly enhanced by the use of  $\sim 50$  watts of 2450 MHz ECRH preionization.

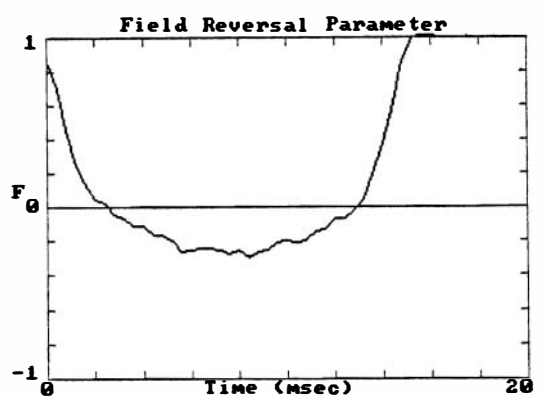
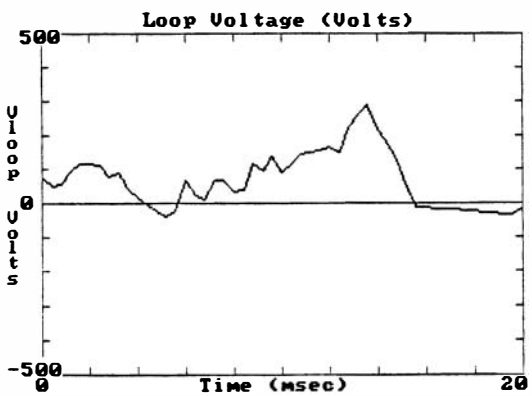
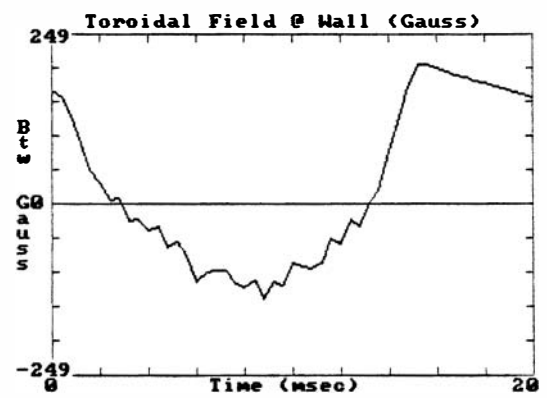
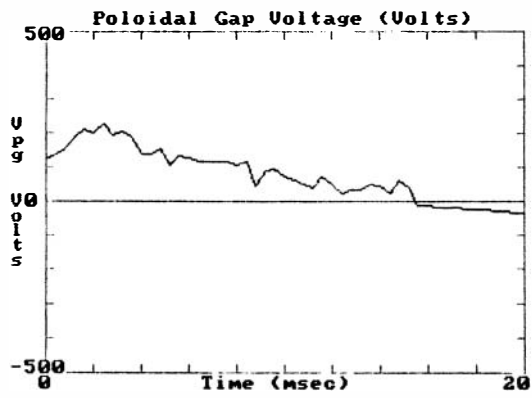
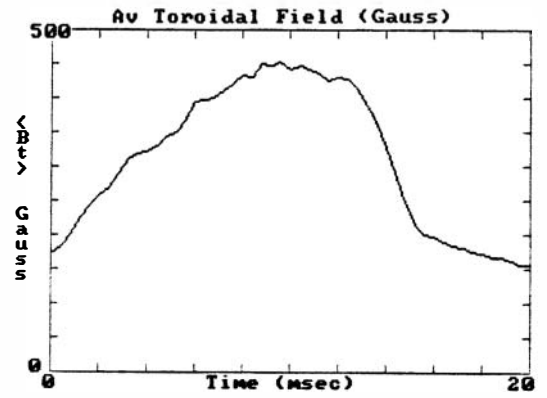
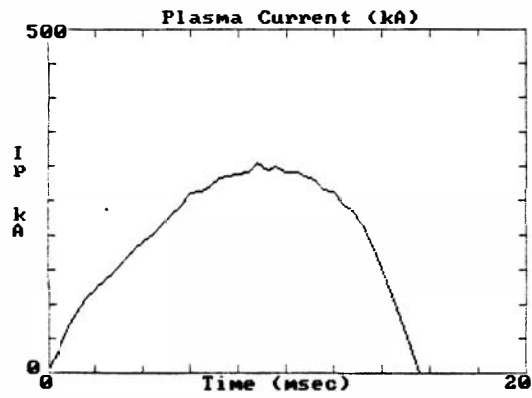

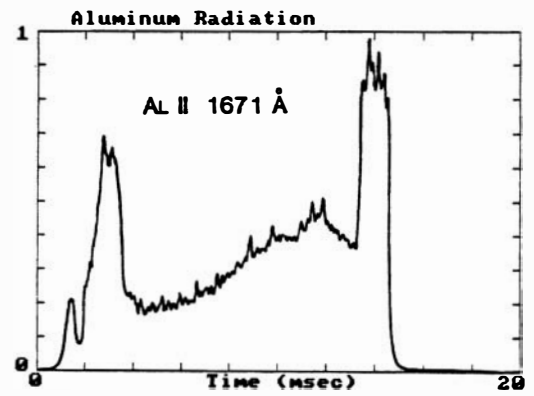
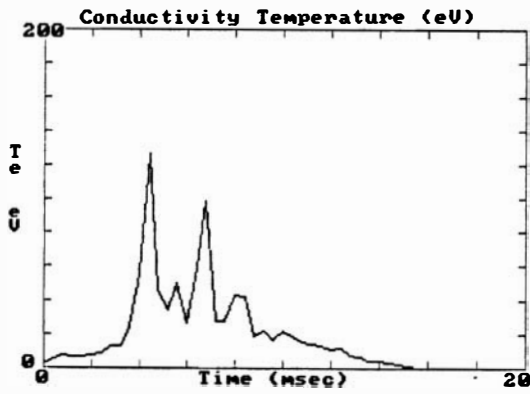
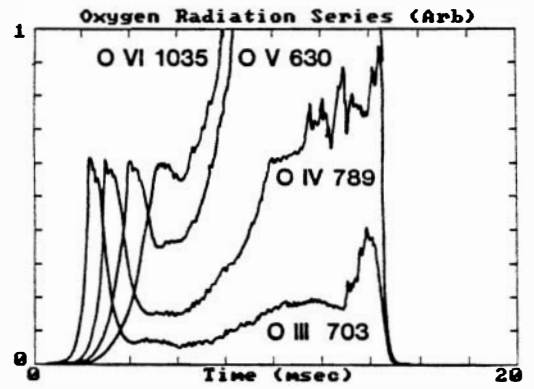
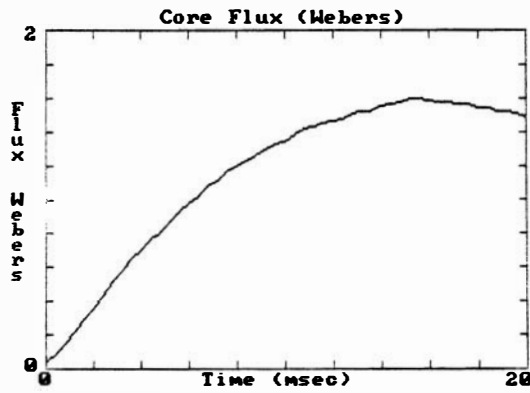
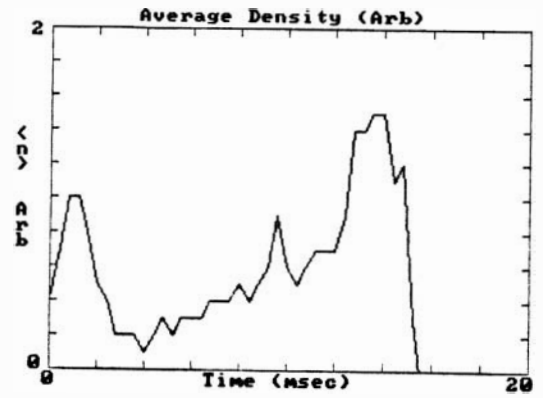
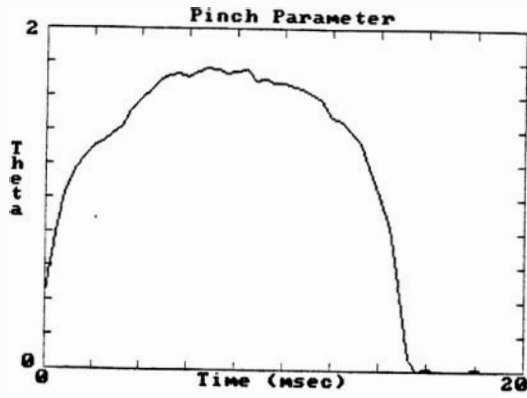



# C III 4647 Å DOPPLER PROFILE

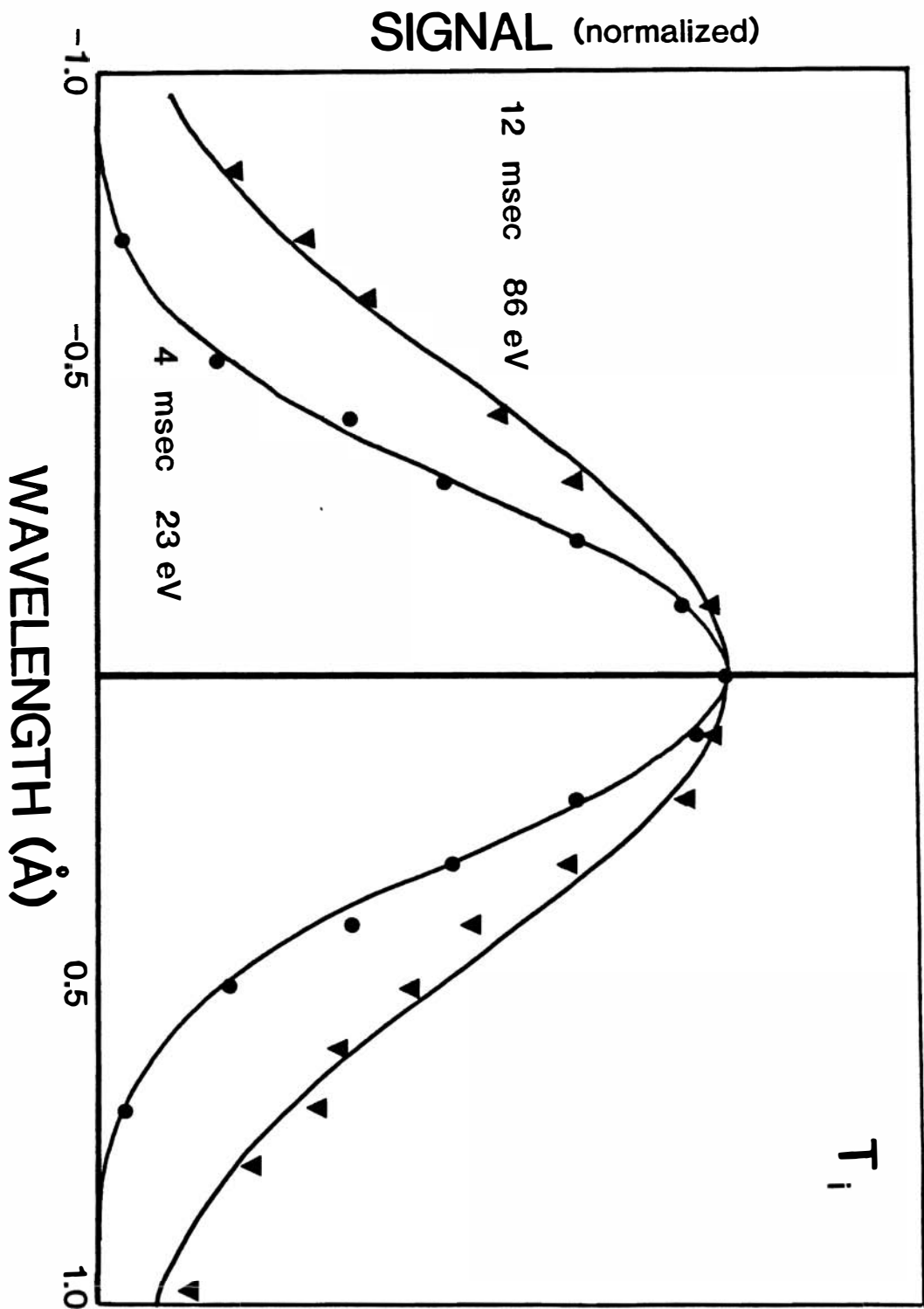

# Field Reversal Parameter

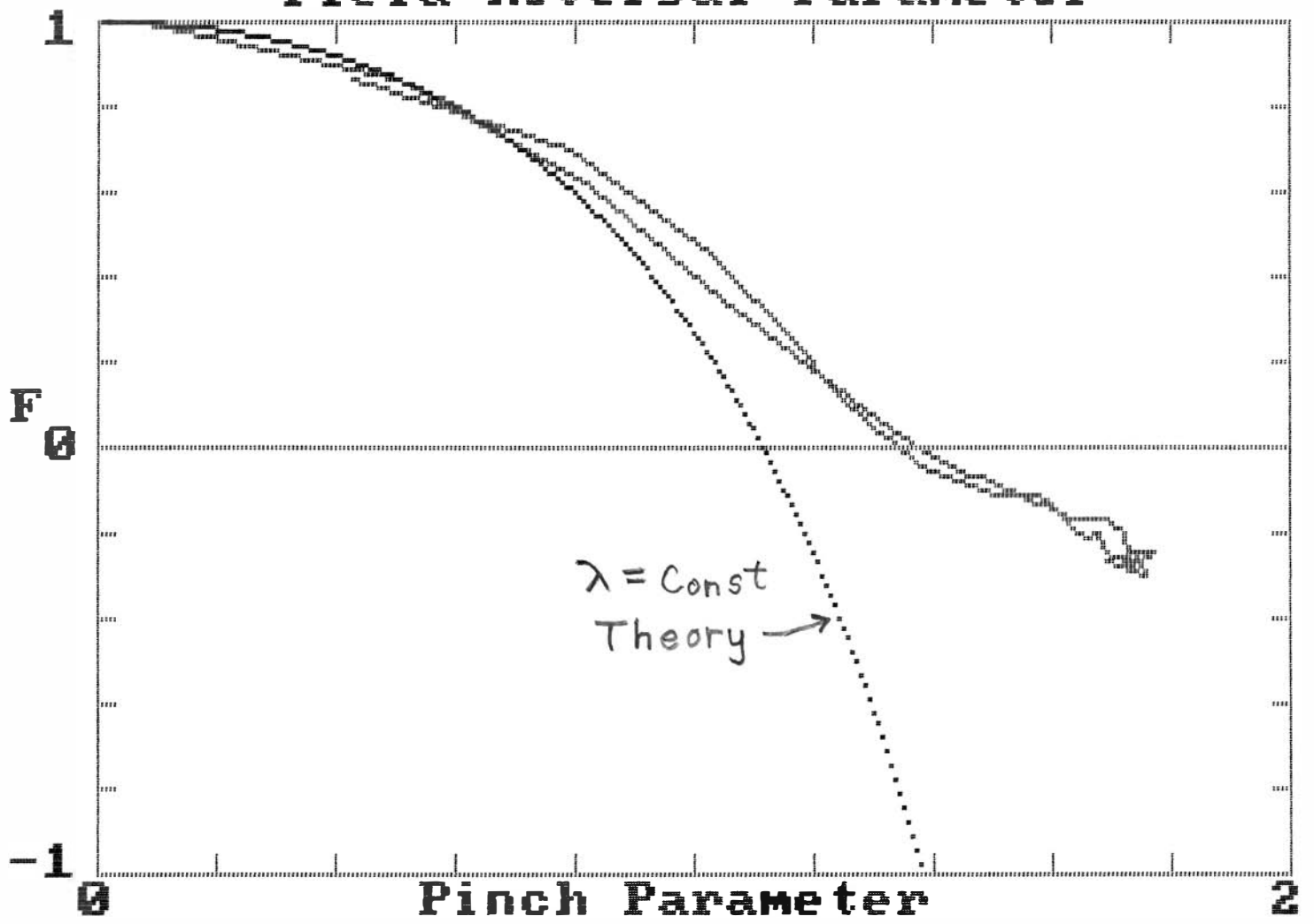

# Field Reversal Parameter

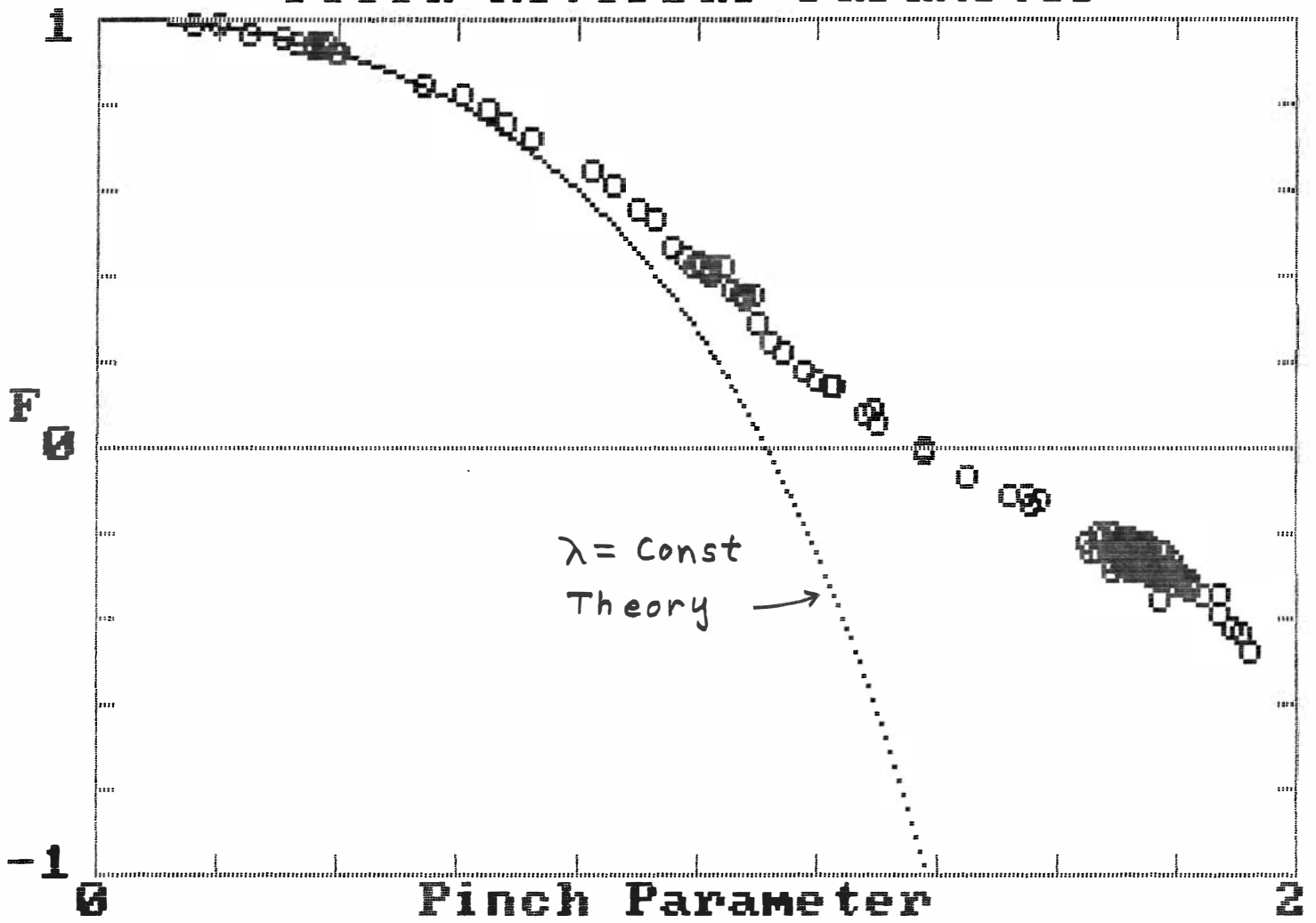

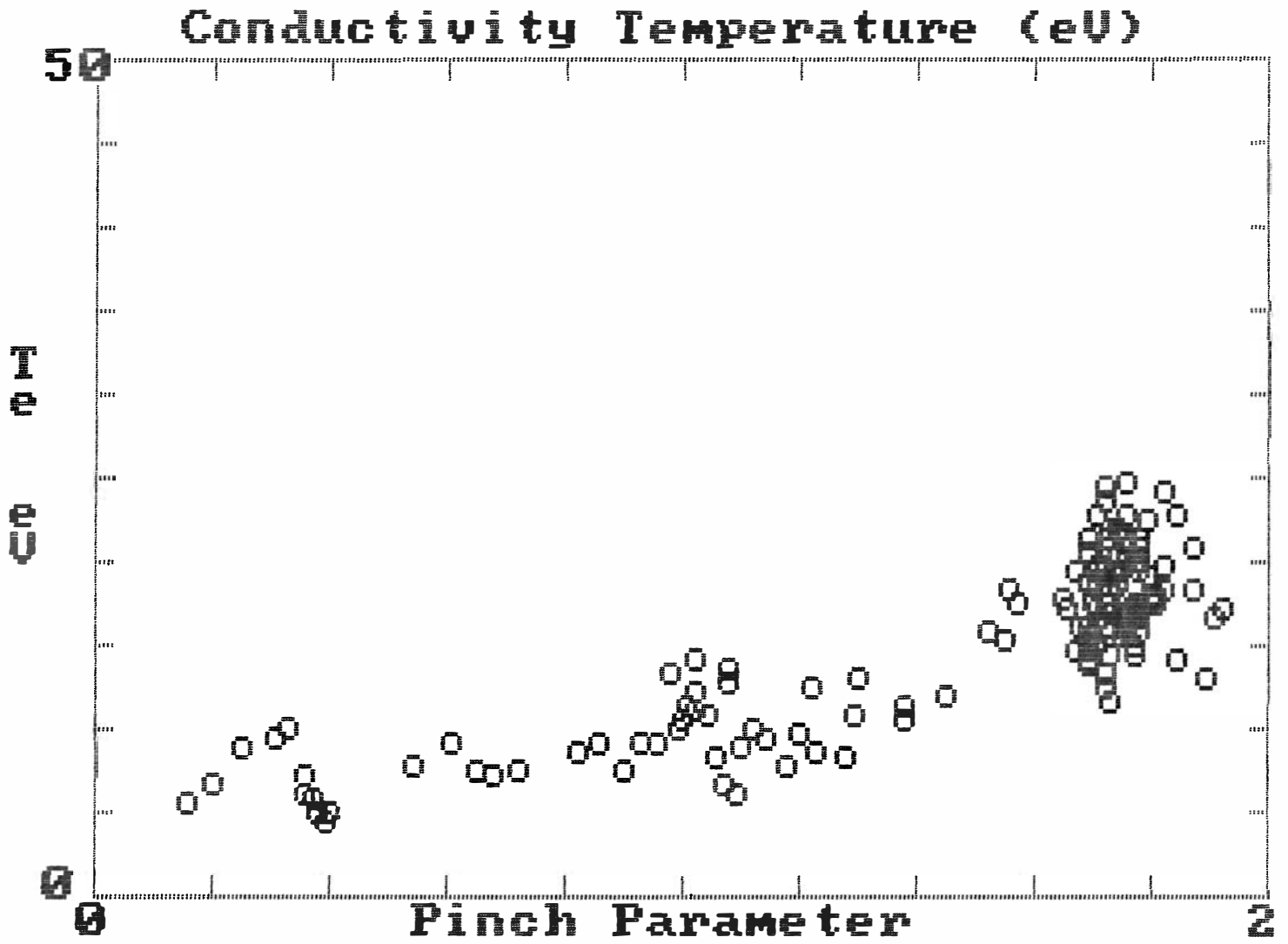

# Plasma Current (kA)

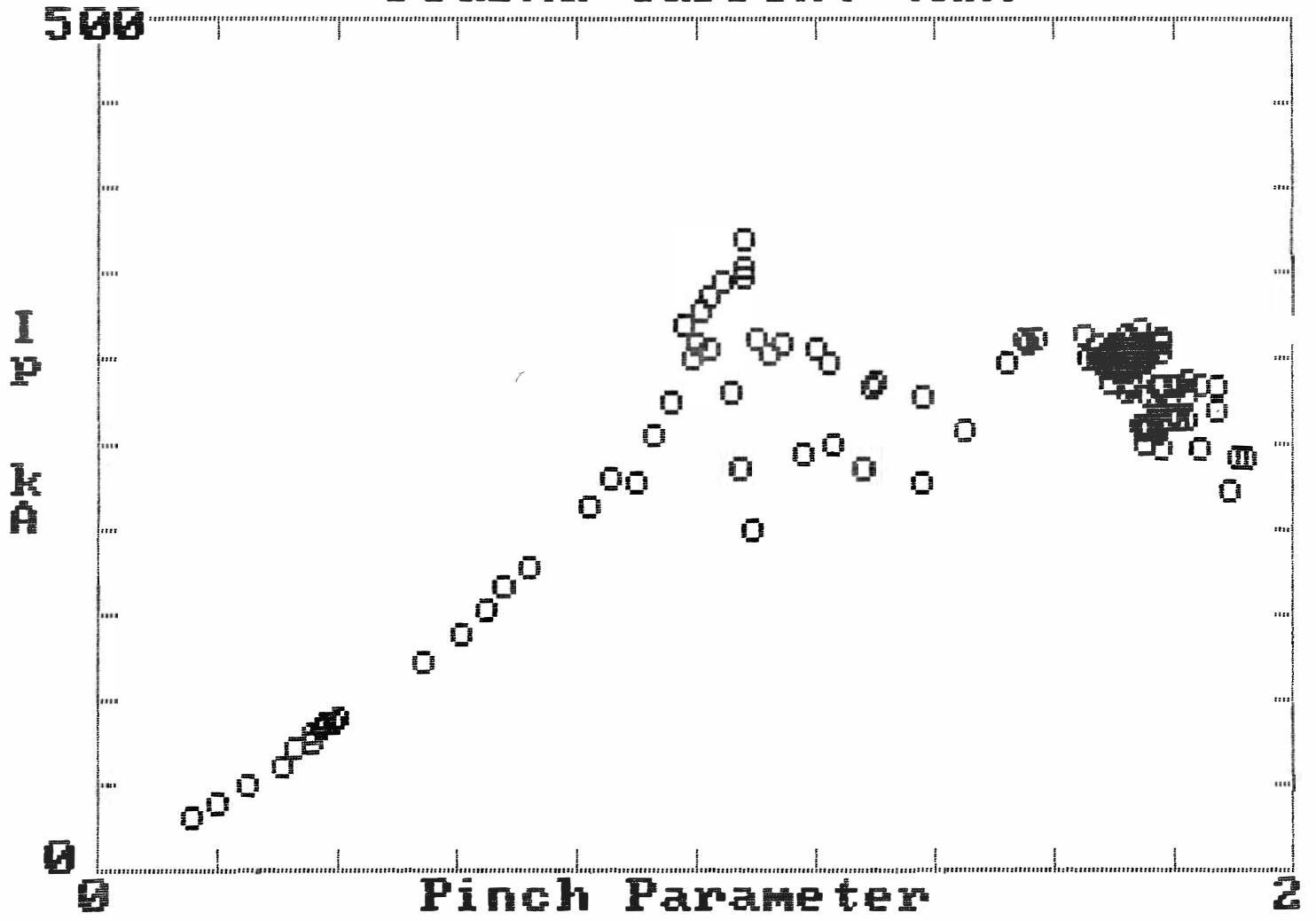

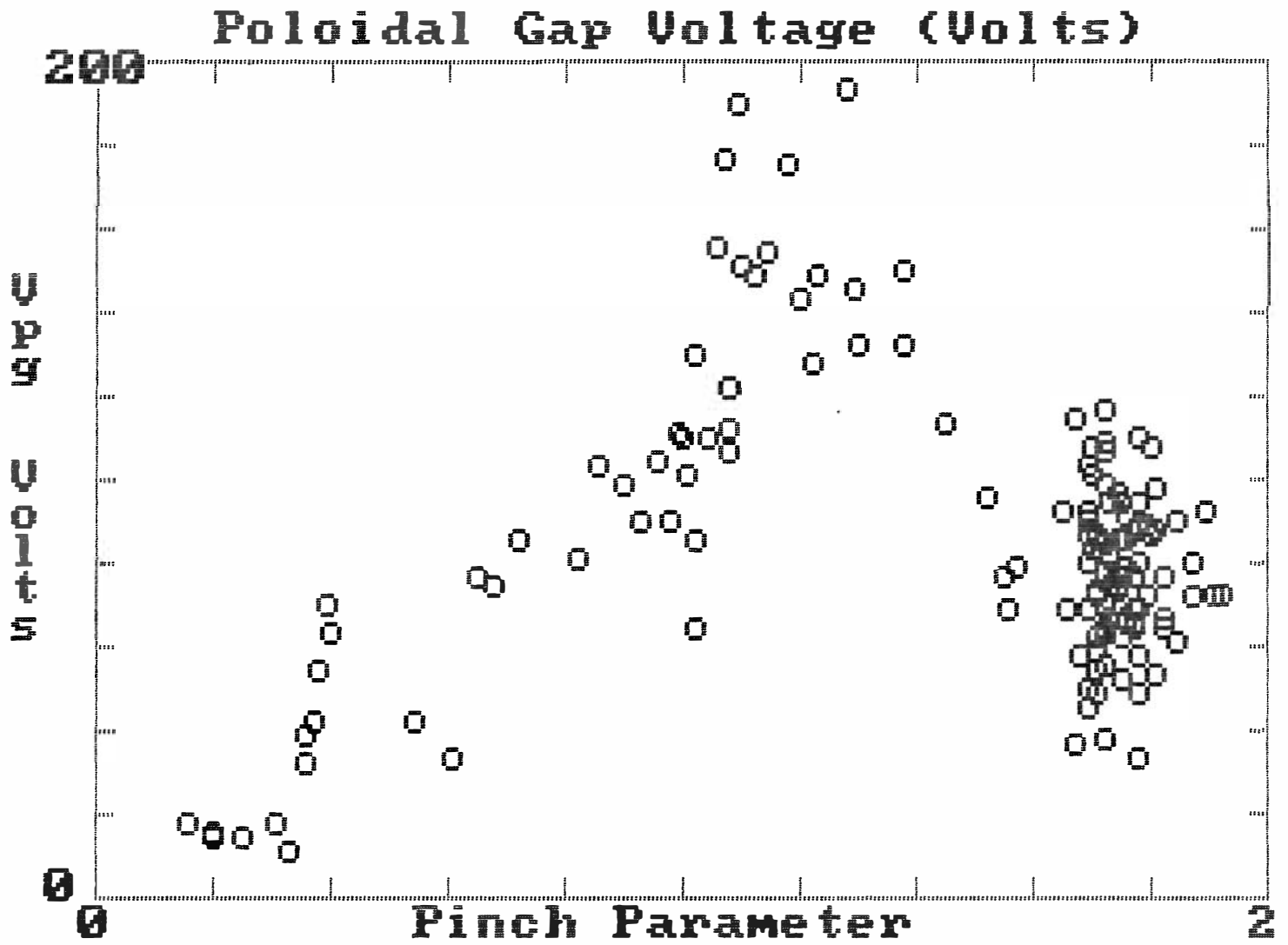

# Poloidal Gap Voltage (Volts)

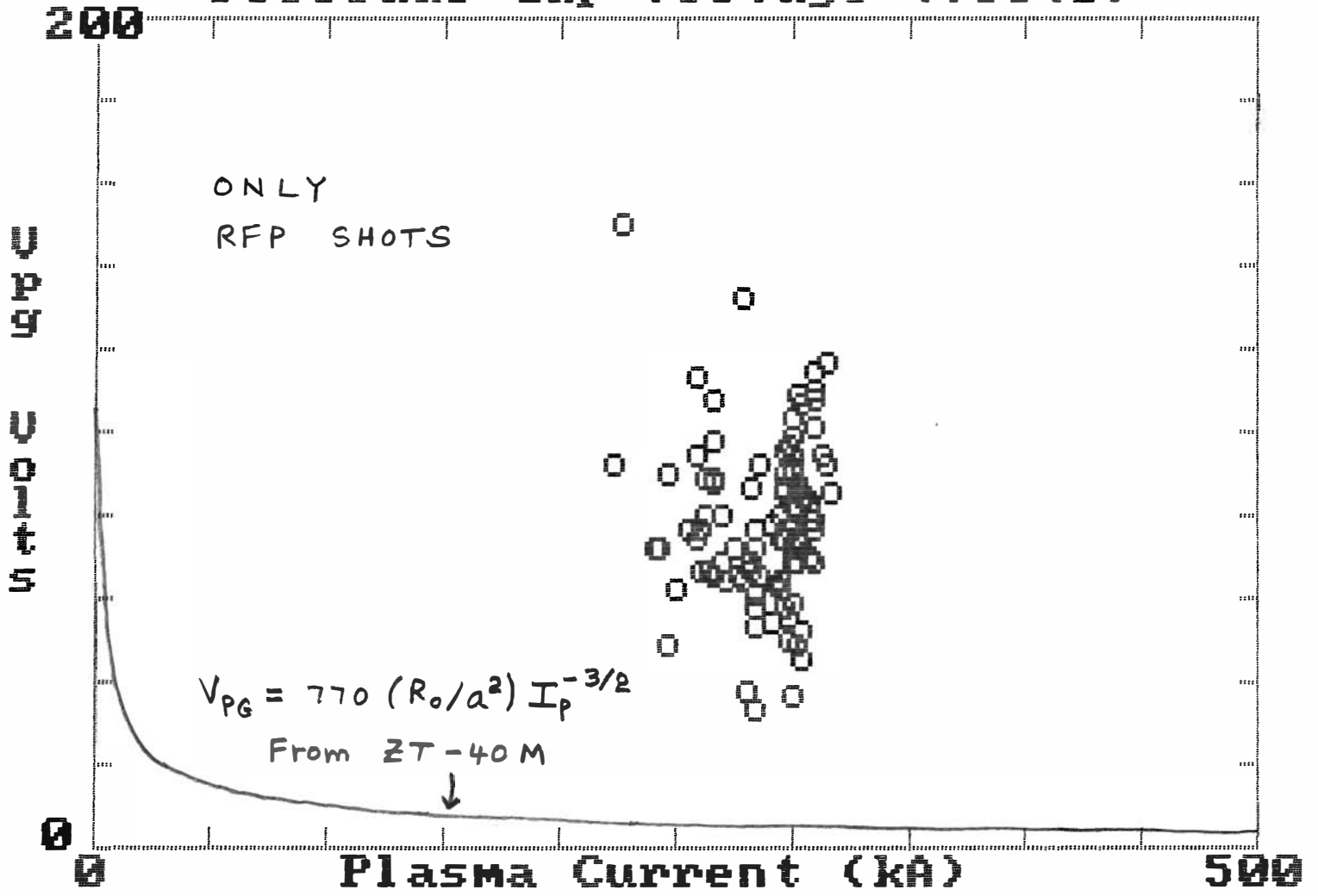

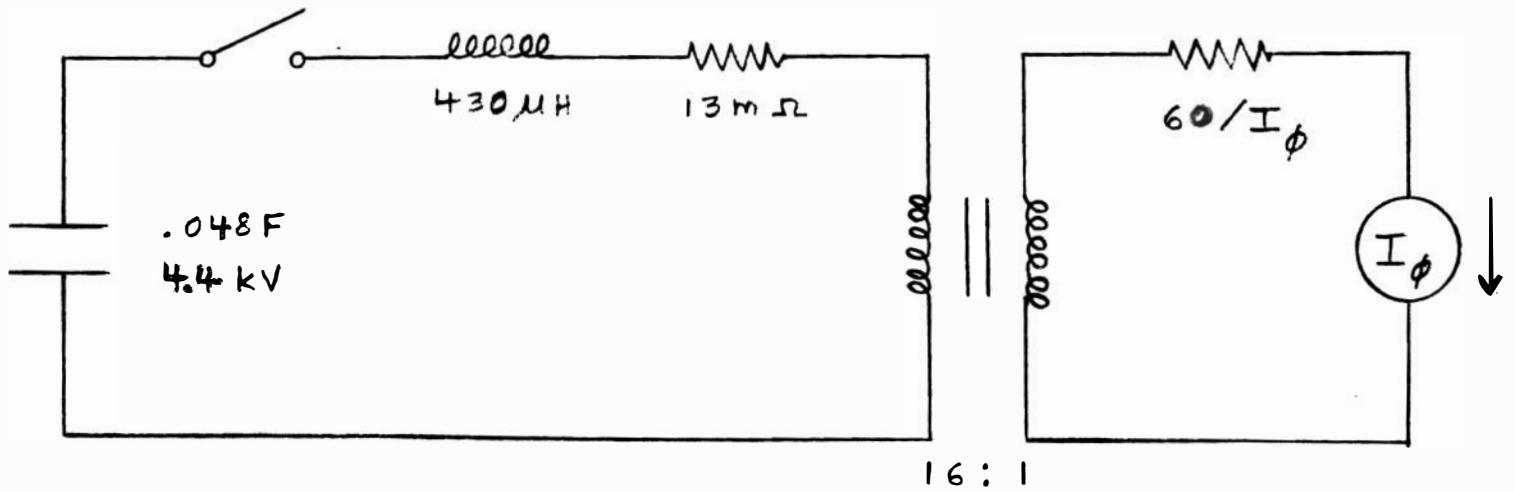

POLOIDAL FIELD CIRCUIT

COUPLED  
VIA  
 $F(\theta)$

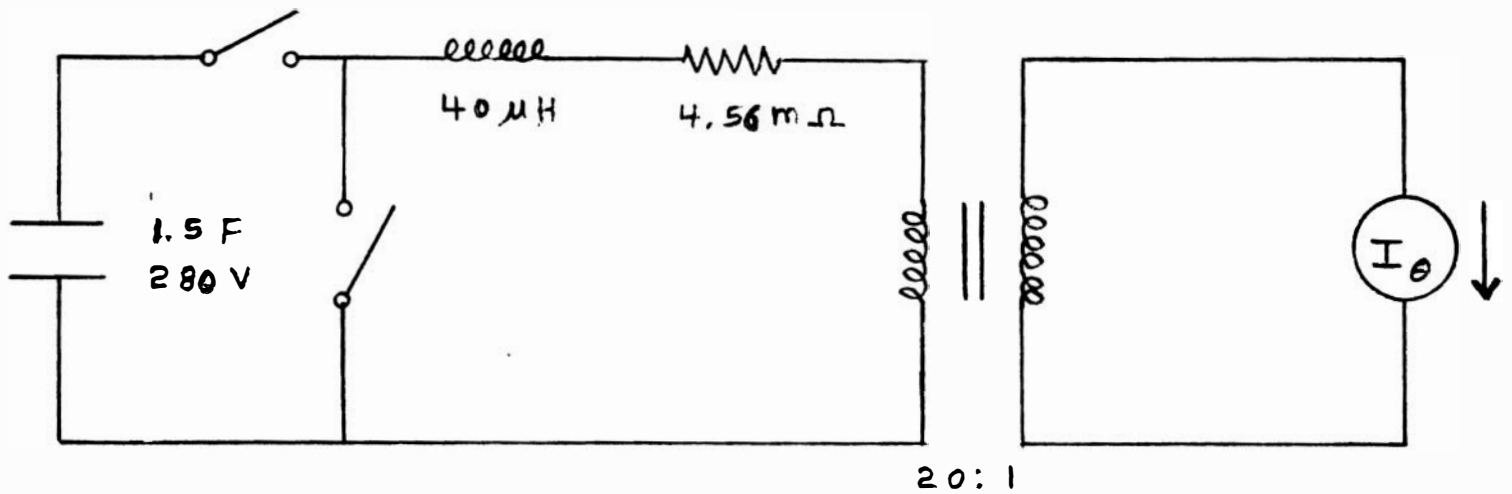

TOROIDAL FIELD CIRCUIT



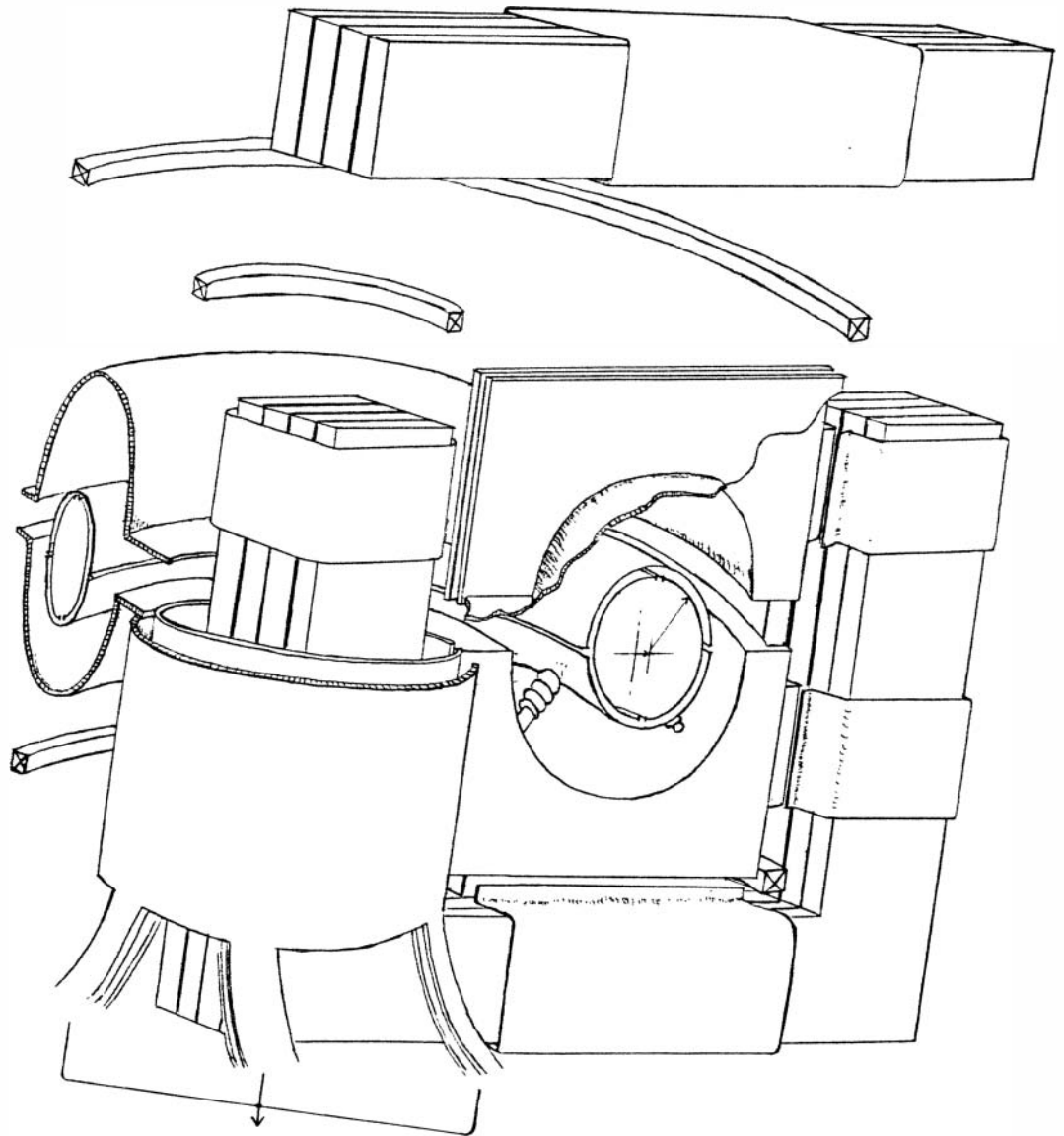

NEAR-TERM PLANS:

Begin installation of new rings	7/86
Start magnetic limiter experiments	9/86
Install Thomson scattering	9/86
Report on magnetic limiter studies	4/87
Begin installation of MST device	4/87
First RFP plasma in MST	10/87
Begin construction of first shell	11/87